



HCO PUMPS

Thermoplastic mechanical seal pumps



INSTALLATION, OPERATION AND MAINTENANCE MANUAL

Translation of the original instructions

(SAFETY INSTRUCTIONS)

INDEX

Summary

INDEX.....	2
1. INTRODUCTION.....	4
1.1 <i>General</i>	4
1.2 <i>Purpose of the manual</i>	4
1.3 <i>Safety Alert Symbols</i>	4
1.4 <i>Qualification and training of operators</i>	4
1.5 <i>Explosive environment</i>	5
2. INSTALLATION.....	5
<i>Premise</i>	5
2.1 <i>General Safety Warnings</i>	5
2.1.1 <i>Premise on the danger</i>	5
2.1.2 <i>Information on hazards</i>	5
2.2 <i>Receipt and Inspection</i>	6
2.3 <i>Storage</i>	7
2.4 <i>Installation and Fixing</i>	7
2.5 <i>Hydraulic system</i>	7
2.6 <i>Pipes connections</i>	7
2.7 <i>Monitoring equipment</i>	8
2.7.1 <i>Pump control in ATEX ZONE 2 explosive environments</i>	8
2.8 <i>Motor Connection</i>	9
3. SERVICE.....	10
3.1 <i>Use and safety</i>	10
3.2 <i>First start-up</i>	11
3.3 <i>Temperature</i>	11
3.4 <i>Before starting</i>	11
3.5 <i>Starting</i>	12
3.6 <i>Optimal conditions of use</i>	12
3.7 <i>Shutdown</i>	12
3.8 <i>Long pump inactivity</i>	12

3.9 Noise level.....	13
4. MAINTENANCE.....	13
4.1 General provisions.....	13
4.2 Inspections.....	14
4.3 Procedure before disassembly.....	14
4.4 Disassembly.....	15
4.4.1 HCO mod 95-10 main parts.....	15
4.4.2 HCO mod 110-200 main parts.....	16
4.4.3 HCO mod 180-200 double seal main parts.....	17
4.5 Disassembly of the pump from the motor.....	18
4.6 Montage.....	19
4.7 Replacing the Motor.....	19
4.8 Tightening torques.....	19
5 TROUBLESHOOTING.....	20
6. SPARE PARTS.....	21
6.1 How to Order Spares.....	21
7. DATA.....	22
7.1 Performance curves.....	22
7.2 Dimensions.....	23
7.2.1 HCO 95/10 - 170.....	23
7.2.2 HCO 180 - 200.....	24
7.4 Technical Data and Limitations.....	25
8. WARRANTY AND REPAIR.....	26
8.1 Warranty.....	26
8.2 Parts Returns and Repairs.....	27
8.3 Decontamination Declaration (facsimile).....	28
8.4 CE Certificate for HCO Series Pumps.....	29
8.5 ATEX/CE Certificate for Zone 2 (facsimile).....	30

1. INTRODUCTION

1.1 General

This manual refers to mechanical seal centrifugal pumps series HCO. Pumps HCO are made of thermoplastic materials (Polypropylene or PVDF) and can be of different sizes.

Dimensions and capacities available are described in paragraph 7.0

1.2 Purpose of the manual

The primary purpose of the manual is to ensure that the installation, use and maintenance of the pumps are carried out correctly and safely by the various operators in charge of these operations. The document also provides useful information to the customer for diagnosing problems, finding spare parts and accessing the repair service offered by GemmeCotti s.r.l.

WARNING: check the [website www.gemmecotti.com](http://www.gemmecotti.com) if any revisions have been released since this manual.

1.3 Safety Alert Symbols



This symbol indicates possible hazards induced by the presence of electric fields, contacts or wires with electric voltage.



The exclamation mark signs in this manual indicate a situation of particular importance that requires operator attention. In particular, they are useful indications for the correct operation and prevention of possible damage to the devices.



This symbol indicates a hazard or situation that requires the operator's full attention. It is essential to follow the instructions provided in the margin of this symbol and proceed with the utmost caution. It is necessary to inform all operators and/or users that the rules indicated prevent accidents.

1.4 Qualification and training of operators



Personnel in charge of the installation, operation and maintenance of the pumps must be qualified to perform the operations indicated in this manual. GemmeCotti cannot be held responsible for the insufficient level of preparation and training of the customer's staff and for the fact that they have not been informed about the contents of this manual. It is essential that operators in charge of the installation, operation and maintenance of the pump always provide this manual. Keep this manual in a safe place for future reference.

1.5 Explosive environment

HTM PP/PVDF standard pumps CANNOT be used in explosive atmospheres. These uses require special pumps that GemmeCotti manufactures with particular materials and precautions. Customers who want to use special pumps in these kind of zones have to contact the GemmeCotti technical office for the correct choice of the product.

The pumps, manufactured by GemmeCotti, for these kind of applications belong to the series EM-CO o EM-C o EM-T o EM-P.

Pump model EM-CO o EM-C o EM-T o EM-P in PP or PVDF can be used only for Atex zone2, group II category 3 G Ex h IIB T6 Gc. Please refer to paragraph 2.7.1 for further instructions.



WE REMIND YOU THAT THE CLASSIFICATION OF THE ZONE (REF. ATEX 2014/34/EU FORMER 94/9/CE DIRECTIVE) FOR POTENTIALLY EXPLOSIVE ATMOSPHERE ZONES HAVE TO BE DONE BY THE CUSTOMER AND COMMUNICATED TO GEMMECOTTI FOR THE RIGHT CHOICE OF THE TYPE OF PUMP SUITABLE TO WORK IN THESE ZONES.

Furthermore, the customer is responsible of the correct installation of the pump in accordance with the requirements stated in the Directive.

2. INSTALLATION

Premise

All references made to pumps are to be considered applicable to systems using these pumps unless otherwise specified.

2.1 General Safety Warnings ⁵

2.1.1 Premise on the danger



WARNING: Failure to follow the directions in this manual or improper use of the equipment by unqualified and unauthorized personnel could result in serious personal injury or death and damage to products and property!

The technical assistance service is at your complete disposal; for any doubts or problems you can contact us by phone at +39 02 964.60.406 or write an email to info@gemmecotti.com. It is strongly recommended that you keep GemmeCotti's written answer.

2.1.2 Information on hazards



For the safety of the operators involved in installation operations, it is necessary to use protective clothing and personal protective equipment approved according to current legal provisions (i.e. safety glasses, gloves and insulating and protective footwear against crushing).



These pumps have been designed and built for use in specific conditions and within defined limits. Use outside of these specifications must be agreed and approved by the technical service of GemmeCotti. **It must be considered also that ,if pumps are used outside of their technical specifications, the CE Certification and Warranties are no longer valid..**

⁵ Failure to follow the warnings provided may void the Pump Certification and Warranty

Furthermore, if the pump is used outside the technical specifications communicated in the quote phase and confirmed with our order confirmation, the user assumes all responsibility for the CE certification of the product.



The pump should only be used in the applications specified in the order for which GemmeCotti has selected the model, materials of construction and tested the pump to meet its specifications. For any use other than what is communicated with the order, a written request must always be made to the technical department of GemmeCotti which in turn will respond in writing.



No warranty is provided for repairs or alterations made to the product by users or by third parties not specifically authorized by GemmeCotti.

Always shut down the pump before touching it or carrying out any work on it or in the installation circuit. The pump must be emptied of the pumped liquid, and thoroughly decontaminated with water before carrying out any intervention.



Make sure that the mains power supply to which the pump will be connected is of adequate power and has the correct protective devices (i.e. earthing, circuit breaker).

Always disconnect the electrical supply before working on the pump for maintenance or replacement of parts.



Always keep a fire extinguisher in the vicinity of the pump installation.



Always take extreme care when performing maintenance tasks on pumps and related circuits when they are used with hazardous liquids.

The use of an electric starter is recommended. A simple switch may not be enough to start and stop the electric motor connected to the main power line. An appropriate starter:

- it allows you to prevent accidental starting after a failed starting attempt;
- provides a safe switch, protected against water;
- protects the electric motor against overloads from short circuits (a fuse only protects the wires);
- resists overload starting on the motor, preventing dangerous electric arcs and premature wear of the electrical contacts.

2.2 Receipt and Inspection

Although all precautions have been taken before packing, we recommend that you carefully check the material received. Review all items on the packing list. Make a written report immediately for any damage or deficiencies attributable to the carrier and/or GemmeCotti.

ATTENTION: Check the nameplate data of the pump received and compare them with those relating to your purchase order. Also compare the dimensional correspondence (through the overall drawing provided to each customer)

If the pump has been supplied with the motor, remove the protective shield of the motor fan and try to rotate the motor shaft by hand. If you feel a strong resistance to rotation or if you hear abnormal noises, call your trusted dealer or directly the GemmeCotti assistance service.

2.3 Storage



If the pump is kept in the warehouse, make sure that this is done in a non-humid and sheltered location; Always use the original packaging or equivalent protection. If the pump is left in storage for very long periods and/or in particularly humid environments, the use of hygroscopic substances (silica gel) is recommended to prevent damage.



Do not remove the flange protections until the time of installation and if not already closed, plug the holes in the intake/delivery and air connection manifolds to prevent the intrusion of foreign bodies.



It is warned that prolonged storage time of the pumps may result in:

- degradation of the engine insulation due to moisture absorption
- Degradation of gaskets

2.4 Installation and Fixing



GemmeCotti s.r.l. cannot be held responsible for damage to persons or objects caused by improper installation or carried out by unqualified personnel.

Install the pump in a location that allows for easy service.



The motor/pump unit must be fixed on a rigid structure that allows the entire structure to be supported. The suction and delivery pipes must not weigh on the nozzles/flanges of the pump. The load of these pipes must be unloaded on special supports positioned just before the delivery and suction of the pump. Make sure that the pump is fixed on a surface, if necessary use the bases supplied by GemmeCotti or shims under the motor support bases. Where deemed necessary, use "bumpers" to reduce vibrations towards the fixing surface.

2.5 Hydraulic system

The pump is generally part of a hydraulic system that can include a number of components such as valves, equipment, filters, expansion joints, tools, etc. The way the implant is performed and the placement of its components has a great influence on the operation and life of the pump.



It is advisable to wash the newly built systems internally before installing the pump damage to remove any processing residues to prevent them from entering it and damaging it.

2.6 Pipes connections ⁶



Position the pump as close as possible to the source of the liquid to be handled and below the level of the liquid itself (under the head).



Always use pipes as short and straight as possible and limit the number of bends assuring radius of curvature as large as possible. Avoid turbulence and air siphon that can be created in the long piping line. Avoid the creation of siphon also before the suction of the pump.



The pipes must be supported and kept in line independently of the pump, up to its connections,

⁶ Failure to follow the warnings provided may void the warranty terms on the pumps supplied.
 GemmeCotti srl via Po 23/25/27 - 20031 Cesate (MI) - ITALY EU - tel. +39 02 964.60.406 -
 fax +39 02 964.69.114 - info@gemmecotti.com - CF. P.IVA - VAT IT 02057740124

so as not to burden it.



The piping should be properly supported and kept in line independently from the pump, until its connections, so that the piping doesn't exert loads on the pump.



The sizes of the suction and discharge pipes have to be at least as large as the inlet connection of the pump. Diameter restriction of the suction pipe is responsible and cause of the cavitation of the pump, creating a loss in the performance of the pump and a rapid wear. It's advisable always to use (if in case) flexible reinforced pipes that don't collapse under a situation of depression.



Don't use metallic piping with plastic pumps.



Tightening the pipes on plastic pumps must be carried out without the use of tools. Make sure the connections are carefully tightened otherwise the suction capacity will be reduced.



A pressure gauge should be installed in both suction and discharge piping. Installing pressure gauges will allow the operator to easily check the correct operation of the pump in relation to the required operating point. In the event of cavitation or other malfunctions, noticeable pressure fluctuations will be observed.

2.7 Monitoring equipment



Depending on the importance of the pumping circuit, it may be useful to maintain strict control over the performance and condition of the process. The use of pressure measuring instruments on the suction and discharge circuits may be recommended.

The measurement of the electrical power absorbed by the motor can also be measured by means of the use of a wattmeter.



If the temperature of the pumped liquid can be a critical element, insert a thermometer into the circuit, preferably on the suction line.

These control instruments can warn you of any abnormal pump operating situations such as: accidentally closed valves, missing liquid, overloads, etc.

2.7.1 Pump control in ATEX ZONE 2 explosive environments

In addition to the general warnings stated in this manual, special pumps used in potentially explosive areas have to be installed with control equipment specified in this paragraph to maintain a strict monitoring of the performances and process conditions. The control equipment mounted near the pump has to be certified for the same hazardous zone as the pump installed unless it's protected by an airtight closure cabinet also certified.

The installation of pumps type EM-(C-T-P) for use in potentially explosive areas has to follow the rules stated in the ATEX 2014/34/EU Directive.

In particular the requirements referred to the manufacturer applicable to apparatus of Category 3 of Group II (explosive atmosphere due to gas, vapours or mists presence) are the following:

- the devices have to be designed and manufactured so that they avoid trigger sources predictable during normal functioning.
- During expected functioning conditions, the surface temperatures must not exceed the maximum design temperatures indicated in paragraph 3.1. An eventual

overcoming is endurable, in exceptional cases, if the manufacturer adopts extra special protections.

The temperature classes are defined as follows:

Temperature according ISO80079-36	class to	Temperature Limit of the liquid
T6 (85°C)		60°C
T5 (100°C)		75°C
T4 (135°C)		110°C
T3 (200°C)		175°C

- Ambient temperature must be between -20°C and 40°C as per ISO 80079-36
- The temperature of the fluid must be monitored in suction.
- Attention: the table with the temperature ranges is valid only in optimal conditions of use of the pumps (rpm, flow rate, head and NPSHa) of correct lubrication and maintenance.
- In any case, the fluid temperature must not exceed the pump's maximum or minimum design temperature (see section 3.1)



It is NOT recommended to mount the filter on the suction line to avoid obstruction of the suction of the pump which can cause cavitation and/or dry running. A suction filter can only be useful in the start-up phase of the system, for cleaning it, and in any case it must be monitored to avoid blockages which would lead to the incorrect functioning of the pump.



If unacceptable working conditions are revealed, the pump has to be automatically stopped and checked.



The NPSHa may decrease as a result of the installation of a valve or bends, filters, elbows on the suction line, in this case it is necessary to install a flow meter to check for any variations.



The pump is equipped with a conductive ring and so with an accurate ground connection of the ring there can't be unwanted electrostatic charges, sources of explosion trigger.



Pumps supplied for ATEX zone 2 must be coupled to suitable Ex-proof motors.

2.8 Motor Connection

Check that the voltage and frequency on the motor label match those of the mains supply you are to use.



Never connect the electric motor directly to the main line but protect the dedicated line with a suitable main switch with the appropriate protections for safety and overloads.



Electrical connections should always be made by a qualified experienced electrician. The motors supplied must be powered with three-phase voltages or, if required by the customer, single-phase. The type of connection in three-phase motors can be star (Y) or delta (Δ) according to the 400 or 230 VAC power supply line (see figure 1).

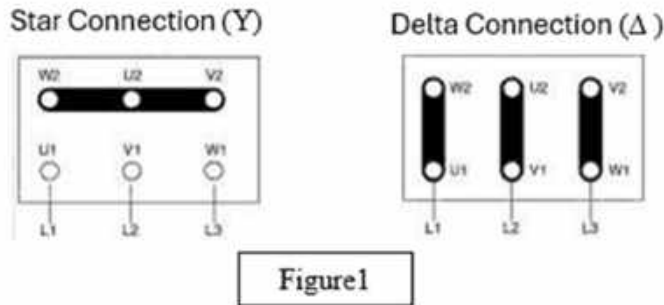

Make sure that the direction of rotation of the motor is as desired. See the WARNING in point 2.6 ; to reverse the direction of rotation, it is sufficient to invert two of the three input lines (e.g. L1 with L2) in three-phase motors.

Remove the engine cover and make sure that the Belleville washer is positioned on the fan side. If not, move it to the correct position.



To test the direction of rotation follow these instructions:

- wear approved personal protective equipment (i.e. goggles, gloves)
- ensure that the conditions of use comply with the pump specifications (see section 8)
- Install the pump in the hydraulic system
- Fully open the suction and the loading valve
- Allow the liquid to flow inside the pump. It is recommended to carry out this test with an inert liquid such as water.
- never allow the pump to run dry (N.B. the design of the pump with magnetic drive does not allow dry operation as this would irreparably damage the internal components of the pump)
- power the motor only for one or two seconds to observe the direction of rotation that complies with the arrow on the motor and pump and indicated on the technical drawings of the pumps. (clockwise looking from the pump intake and counterclockwise looking at the motor fan)

NOTE: A pump that turns in reverse will still pump but with a flow and pressure much lower than the data on the nameplate.

3. SERVICE

3.1 Use and safety

ATTENTION:

Dangerous or risky practices can cause serious injury or death to persons or serious property damage, it is therefore essential to ensure compliance with all safety and correct use warnings provided in this manual.



Always check that the fluid being pumped is compatible with the materials of construction of the pump. Check that the pump you receive corresponds to what you ordered by means of the dimensional check (dimensional drawing) and compare the data on the pump plate with the data provided when ordering. For any clarification, contact the technical office of GemmeCotti.



When used for pumping aggressive, toxic or health-threatening liquids, adequate protection must generally be installed on the pump for containment, collection and signalling of the hazardous product in the event of spillage: e.g. DANGER OF POLLUTION, CONTAMINATION, INJURY AND/OR DEATH.



It is **NOT RECOMMENDED** to mount a suction filter to avoid obstruction to the suction that can cause cavitation and/or dry running. A suction filter can only be useful in the start-up phase, for cleaning the same and in any case it must be monitored to avoid clogging that would lead to the correct operation of the pump.



- Never restrict your intake. Narrowing on the suction is responsible for the cavitation of the pump, which leads to a loss of efficiency and rapid wear
- Narrowing of the discharge is not advisable, reductions in the flow rate, if required, can be obtained by means of a valve installed on the delivery pipe.
- Never loosen the pump connections while it is under pressure.
- Do not start and/or run the pump if there are traces of leaks in the circuit

The operating temperatures must be such as to comply with the characteristics of the construction materials used in the pump:



- 0- 60 °C polypropylene (PP) design
- 0- 80 °C PVDF design



NEVER RUN THE PUMP DRY (N.B. the design of the pump does not allow dry operation as this will irreparably damage the internal components of the pump)

- An accidental failure can generate splashes up to a considerable distance.
- In case of vibrations or abnormal noises, stop the pump immediately.
- Do not pump flammable liquids.
- Do not touch the pump while it is running.
- Before touching the motor or bracket, turn off the power.

3.2 First start-up



Fill the pump with water (if compatible with the process liquid) or with the liquid to be pumped before starting the pump. This will protect the mechanical seals and pump shaft against dry running. **NEVER RUN THE PUMP DRY** as serious damage can be caused by lack of lubrication to the internal components of the pump.

3.3 Temperature



Increasing the temperature of the fluid being handled may damage the pump and/or the system pipes and may cause a situation of serious danger to people in the vicinity. Avoid sudden changes in temperature and do not exceed the temperatures specified in the order. See the temperature values of the pump construction materials in section 3.1.

3.4 Before starting

Be sure that the pump is installed in accordance with the instructions given in section 2 above.



When the pumping station is new, the system should be filled with water (or other inert liquid) to check for leaks. **IF THE PUMP IS**

MOUNTED ABOVE THE HEAD, IT MUST BE PRIMED, I.E. FILLED WITH LIQUID, AND THE SUCTION PIPE MUST BE KEPT FULL OF LIQUID BEFORE START-UP



WARNING: Some liquids react with water. **CHECK IF THE LIQUID TO BE PUMPED REACTS WITH WATER. IN THIS CASE, THE SYSTEM MUST BE COMPLETELY EMPTIED AND DRIED.**

3.5 Starting

- Start the electric motor and open the delivery duct gradually until the desired flow is achieved.
- The pump may not run for more than two to three minutes with the discharge circuit closed. A longer period may cause serious damage to the pump.
- If the pressure indicated by the output control tools does not increase, turn off the pump immediately and release the pressure gradually.
- Repeat the pump installation operations as per paragraph 2.
- If during the start-up phase there are changes in the flow rate, density, temperature or viscosity of the liquid, stop the pump and contact the technical assistance service of GemmeCotti s.r.l..

3.6 Optimal conditions of use

By operating continuously at the extreme limit of the pump's characteristic curve (maximum pressure with the valve fully closed or maximum flow rate with the valve fully open at the end of the curve), premature pump wear may occur. As a good practice, we recommend using the pump at half its maximum flow rate (see section on technical data).

In any case, never let the pump work out of curves.



The flow rate and head of the pump refer to pumping water at room temperature. If liquids are to be pumped at high temperatures or high viscosities and densities, the performance must be correspondingly reduced. The HTT series pumps work well with liquids with viscosities up to 100 CPS⁷ and specific weights up to 1.9 kg/dm³. **IN ANY CASE, BOTH VISCOSITY AND SPECIFIC GRAVITY MUST BE COMMUNICATED DURING THE REQUEST FOR QUOTATION PHASE, THE ELECTRIC MOTOR IS SELECTED FOR THE VISCOSITY AND SPECIFIC GRAVITY COMMUNICATED, IF THEY ARE HIGHER, THE POWER OF THE MOTOR MAY BE INSUFFICIENT.**

3.7 Shutdown



Normally the pump should only be stopped after the outlet valve has closed. If the suction valve is closed earlier, cavitation of the pump can occur.

In the event that the suction is flooded, close the valve after stopping the pump.

In some cases the pump could be used to empty tanks or cisterns, in these cases it may happen that the liquid stops flowing into the pump while it is still working. A pump that operates without liquids (and therefore dry) can be seriously damaged if it is not stopped immediately. For uses of this type, it is recommended to use automatic stop devices or the constant presence of an operator who can promptly stop the pump.

3.8 Long pump inactivity



If the pump remains stationary for a long period, before proceeding with the stop, it is advisable to circulate water in the circuit for several minutes, thus avoiding the risk of internal encrustations or precipitation of solid parts. Then drain the liquid into the pump. Freezing of the liquid inside the pump may cause damage. In any case, check whether the pumped liquid reacts with water. In this case, contact GemmeCotti to verify an alternative solution.

⁷The values quoted are purely indicative and may vary within the HTT series pump family.
GemmeCotti srl via Po 23/25/27 - 20031 Cesate (MI) - ITALY EU - tel. +39 02 964.60.406 -
fax +39 02 964.69.114 - info@gemmecotti.com - CF. P.IVA - VAT IT 02057740124

In cases where the pump is temporarily removed from the system and stored, the instructions given in section 2.3 "Storage" must be followed.

3.9 Noise level

In some circumstances, for example when the pump works with high pressure and low flow rate, the noise increases and can be annoying to personnel working nearby. In this case, it is possible to intervene with:



- earplugs;
- protective ear defenders approved for nearby personnel;
- soundproofing devices for the pump. In these cases, make sure that the ventilation of the motor is guaranteed.

4. MAINTENANCE

4.1 General provisions



During the warranty period, no extraordinary maintenance operation of the pump must be carried out except by personnel of GemmeCotti or authorized by GemmeCotti. All the operations described in the following paragraphs must be carried out only by suitably qualified personnel and following all the warnings included in this manual step by step.

In the event of routine maintenance of the pump (as indicated in paragraph 4.2) the customer is responsible for the correct disassembly and assembly. The warranty is void in the event of tampering with it, use of non-original parts or in the event of practices that do not comply with what is indicated in this manual.

During routine maintenance of the pump, the customer is responsible for checking the pump tightness (hydrostatic test, taking care to comply with the pump PN), mounting bushings and checking that the pump is functioning properly. To tighten the screws, refer to the table in paragraph 4.8 and be careful not to pinch the O-ring.

Clean the outer surface of the pumps using only antistatic devices.



Any operation carried out on the machine must be carried out only after physically disconnecting the electrical supply.



The handling of pumps with weights greater than 16 kg must not be carried out manually, but only using hoists or other suitable means. When moving the machine or parts of the machine, avoid knocks or falls that could damage the devices.



Before disassembling pump parts, make sure that hazardous internal liquids have been properly removed/washed. **THE PUMP MUST BE QUENCHED.**



Be aware that some internal liquids may have dangerous reactions when in contact with water.



When discharging hazardous liquids, make sure that there are no situations that pose a danger to people or the environment.

4.2 Inspections



In general, mechanical seal pumps do not require frequent maintenance or disassembly. Periodic inspections are recommended to check the state of wear of the seal, impeller, shaft and whether the general condition of the internal parts of the pump is good.

The inspection interval is highly dependent on the operating conditions of the pump, the characteristics of the fluid, temperature, materials used and of course the operating time.

Components should generally only be changed when they show obvious signs of wear. If a problem is found or the pump needs a complete inspection, see the "Troubleshooting" and "Pump disassembly" chapters.

4.3 Procedure before disassembly

**ATTENTION:**

If the pump has pumped hot liquids, make sure it has been cooled down before disassembling. The pump may have pumped toxic and/or dangerous liquids, so skin and eye protection should be worn.

**ATTENTION:**

Be sure that you have thoroughly cleared the pump. Flush and neutralize hazardous fluids inside the pump completely. The liquid must be recovered and disposed of according to existing environmental laws. After disconnecting the suction and delivery hoses, close the ends.

4.4 Disassembly

4.4.1 HCO mod 95-10 main parts

The figures below show a section and an exploded view of the parts constituting a pump of the HCO 95-10 model (excluding the motor) in thermoplastic material. Your pump may differ slightly from what is shown

SECTION AND PARTS LIST/SEZIONE E LISTA PARTI

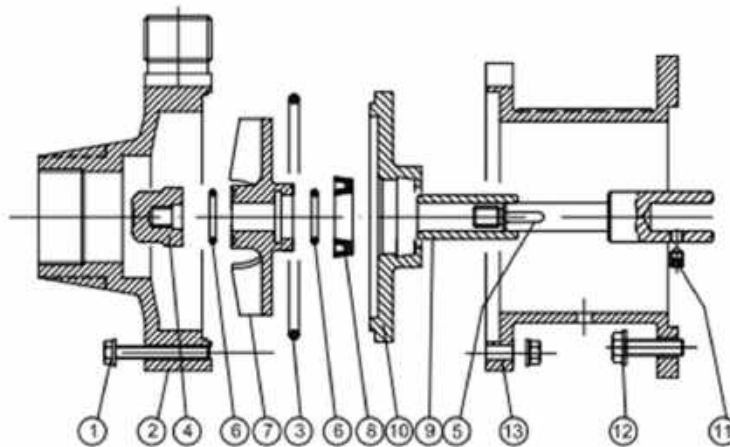

PCS.	1	2	3	4	5	6	7	8	9	10	11	12	13
PART DESCR.	SET SCREWS	PUMP HEAD	O-RING	IMPELLER NUT	SHAFT	O-RING	IMPELLER	LIP SEAL	SHAFT SLEEVE	COVER	GRUB SCREW	SET SCREWS	BRACKET
MAT.	AI9304	PP+GF PVDF+GF	EPDM VITON	PP-PVDF	C40 AIS316	EPDM VITON	PP-PVDF	EPDM VITON	A203	PP+GF PVDF+GF	AI9304	AI9304	PP

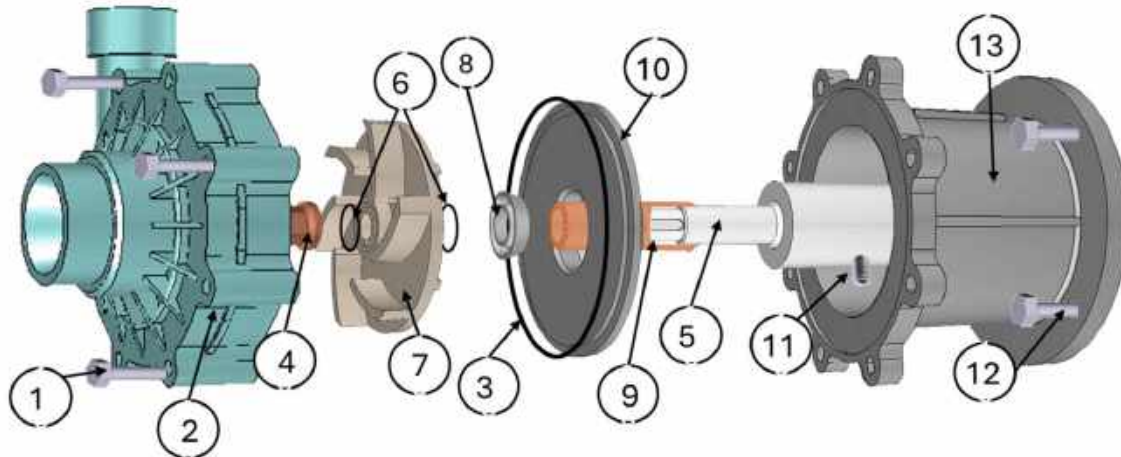

4.4.2 HCO mod 110-200 main parts

The figures below show a section and an exploded view of the parts constituting a pump of the HCO family from 110 to 200 with a single mechanical seal (excluding the motor) in thermoplastic material (in particular the 110 and 140 models). Therefore, the pump you are equipped with may differ slightly from what is shown

SECTION AND PARTS LIST/SEZIONE E LISTA PARTI

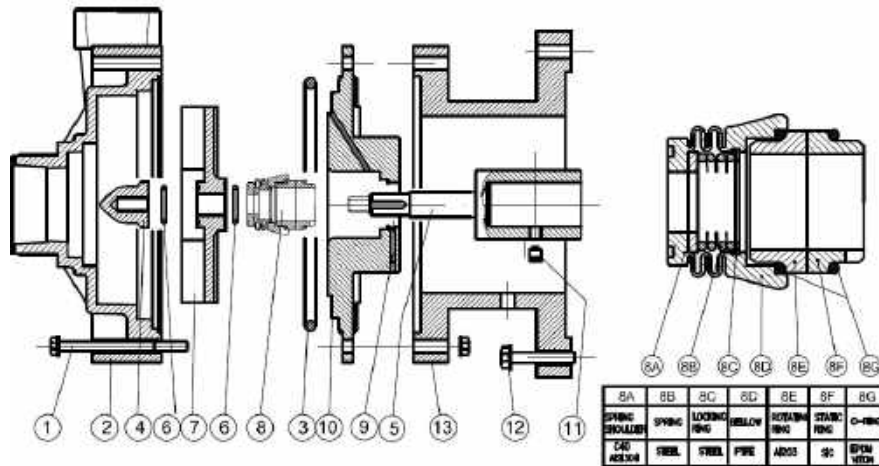

POS.	1	2	3	4	5	6	7	8	9	10	11	12	13
PART DESCR.	SET SCREWS	PUMP HEAD	O-RING	IMPELLER NUT	SHAFT	O-RING	IMPELLER	MECHANICAL SEAL	PN	COVER	GRUB SCREW	SET SCREWS	BRACKET
MAT.	AIN304	PP+GF PVDF+GF	EPDM VITON	PP-PVDF	C40 AIN316	EPDM VITON	PP-PVDF	●	AIN304	PP+GF PVDF+GF	AIN304	AIN304	PP

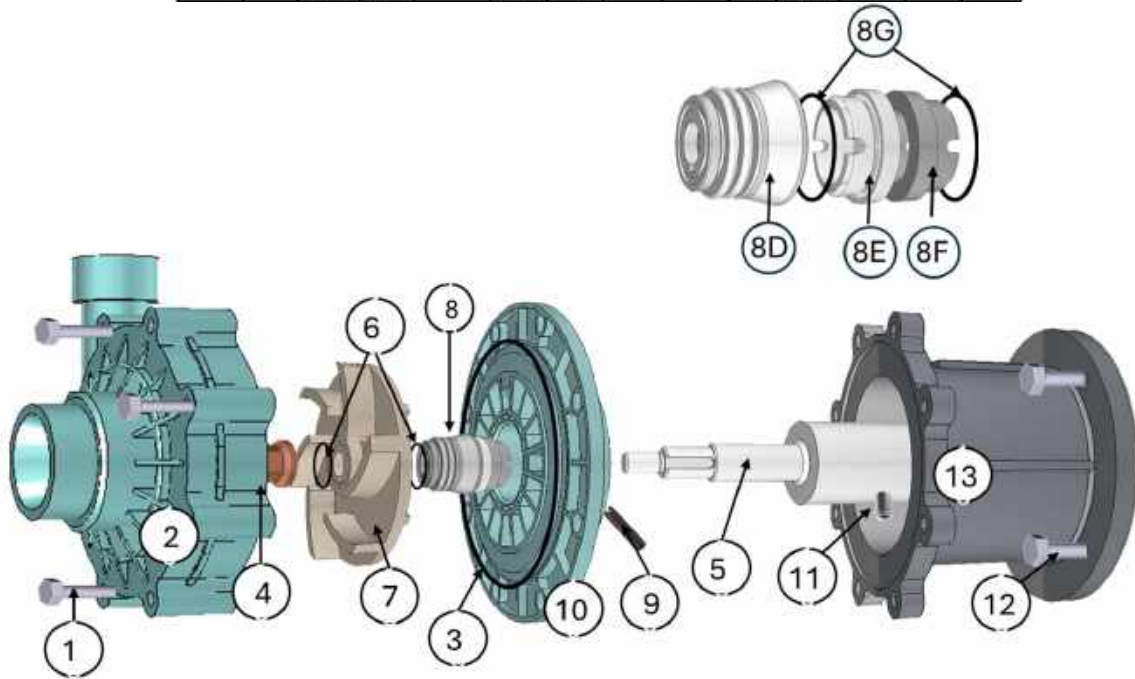

4.4.3 HCO mod 180-200 double seal main parts

The figures below show a section and an exploded view of the parts constituting a pump of the HCO family from 180 to 200 with double mechanical seal (excluding the motor) in thermoplastic material. Your pump may differ slightly from what is shown

SECTION AND PARTS LIST/SEZIONE E LISTA PARTI

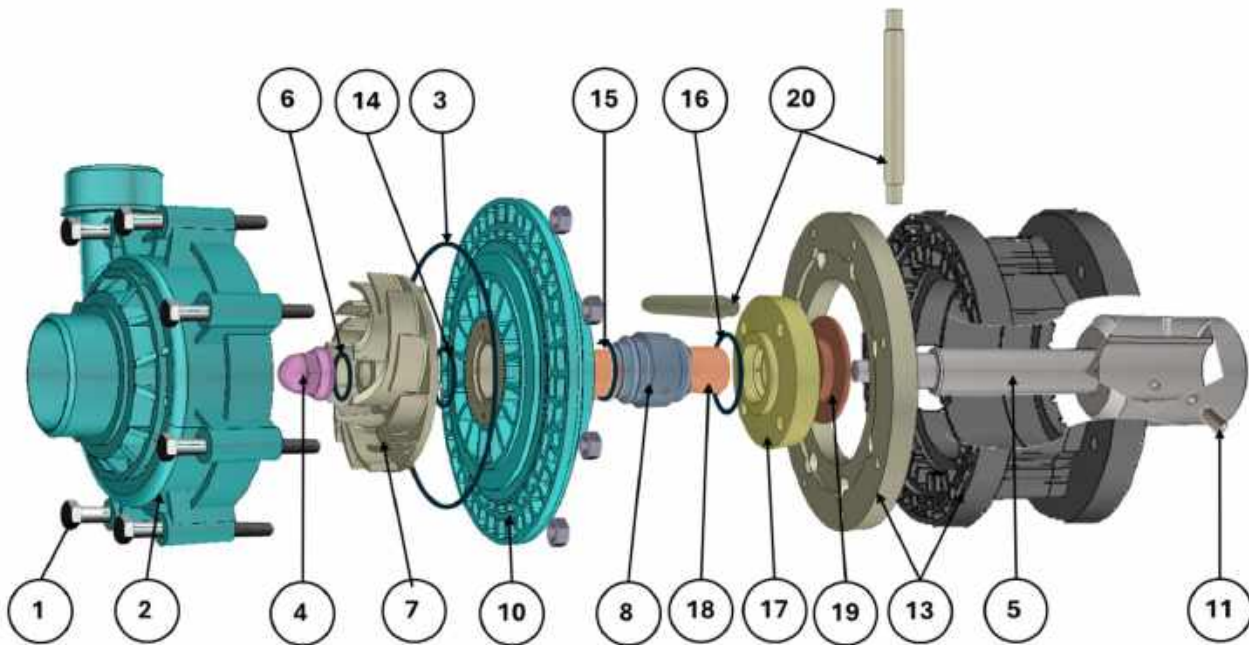
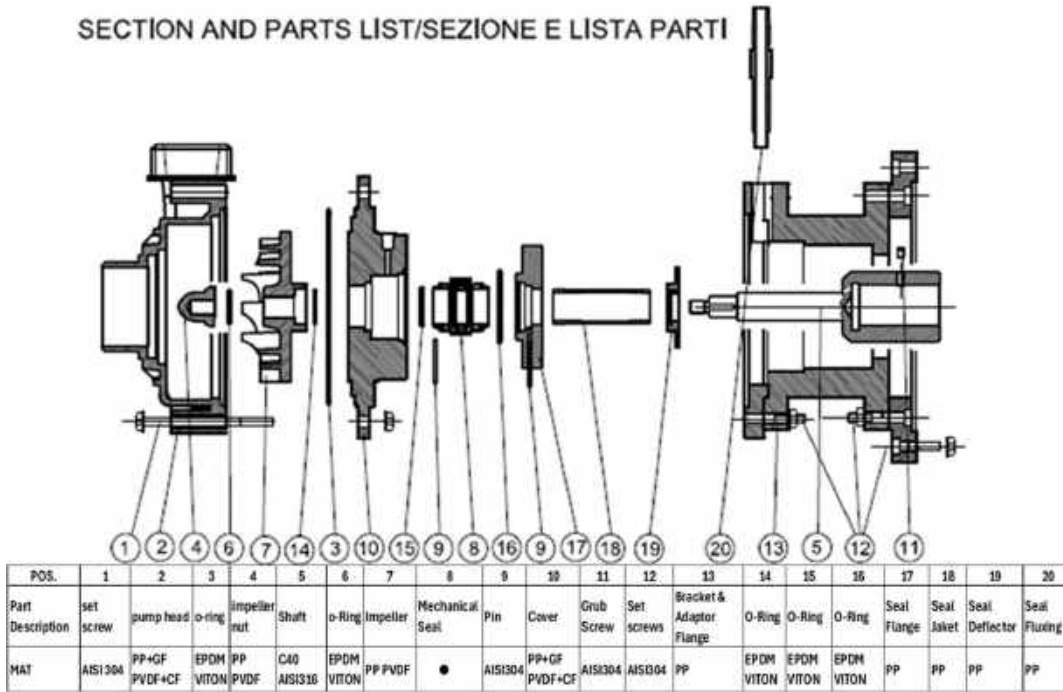

4.5 Disassembly of the pump from the motor

Sequence of operations:

1- Separate the pump housing (2) from the lantern (13) by removing the tightening screws (1) (Figure 1)

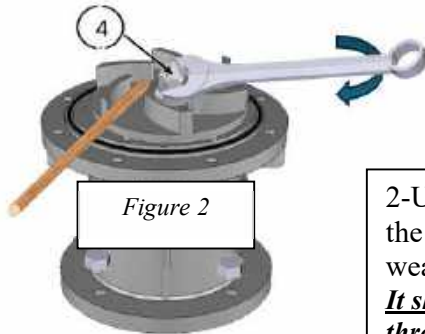

Figure 2

2- Unscrew the impeller lock nut (4), remove the impeller (7) and check the o-rings (6) for wear (Figures 2 and 3)

It should be noted that the impeller (4) has a left thread, so turn clockwise to unscrew it



Figure 3

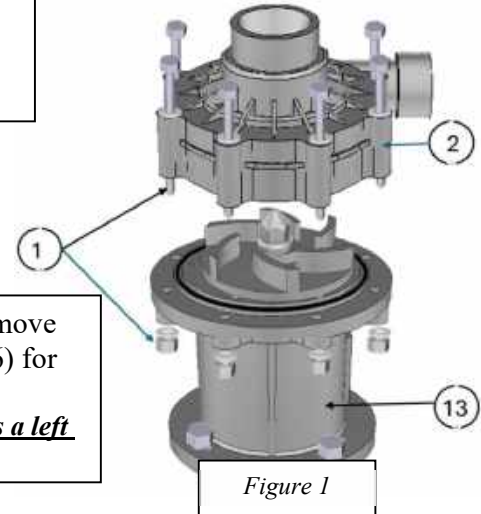

Figure 1

3- After removing the impeller, check the mechanical seal, bellows (8D), rotating ring (8E) and o-ring (8G) for wear (Figure 4). Remove the cover (10) from the lantern and check the condition of the static ring (8F) and o-ring (8G) (Figure 5)

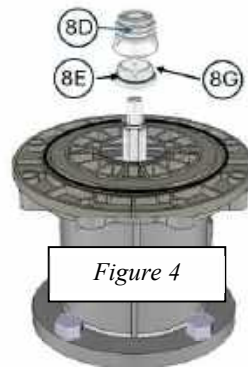

Figure 4

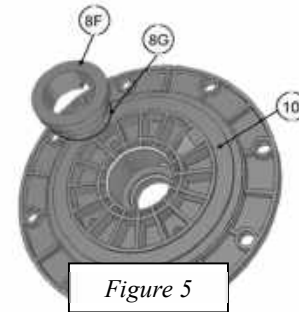

Figure 5

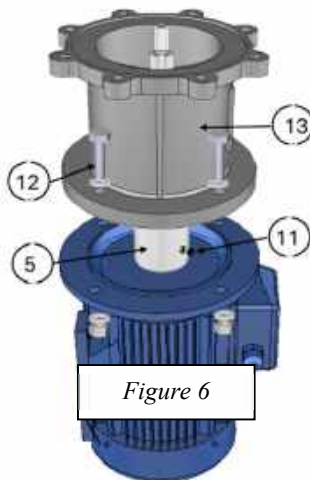

Figure 6

4- After performing these operations, you can remove the screws (12) between the lantern and the motor (Figure 6). The shaft of the HCO series pump is coupled directly to the motor, and locked by an Allen grub screw (11)

The components that can be periodically replaced are:

- O-rings (detail 3 and 6 in the exploded drawing)

- Mechanical seal (detail 8 in the exploded drawing)

4.6 Montage

The assembly sequence is mirrored to the disassembly sequence, but the following warnings must be kept in mind:



ATTENTION:

Clean each component thoroughly before assembly, make sure all parts are free of dirt, metal particles etc

- Make sure that when the pump is closed, the gasket (O-ring) is perfectly seated and is not pinched.
- Use torque wrenches for correct tightening force of the screws according to the table in paragraph 4.8 below.
- After tightening the pump onto the motor flange, momentarily remove the protective fan shield on the rear of the motor and rotate the fan by hand to verify the free rotation of the assembled assembly. If excessive friction or abnormal noise is detected, proceed to disassemble the assembly (operations in paragraph 4.4) and to detect the cause of the anomaly. Under no circumstances should the pump be used without having carried out this check. Reassemble the protective fan before starting the pump.



4.7 Replacing the Motor

Proceed as indicated in the previous paragraph 4.5. Make sure that the characteristics of the motor are equal to those of the replaced motor. The manufacturer of the new motor can be different from that of the motor already mounted.

4.8 Tightening torques

The recommended tightening torques are shown in the table below:

THREAD	COUPLING TYPE	
	PLASTIC / PLASTICPLASTIC / METAL	METAL / METAL
M5	3 Nm	8 Nm
M6	6 Nm	13 Nm
M8	10 Nm	32 Nm
M10	17 Nm	65 Nm
M12	25 Nm	110 Nm
M16	50 Nm	290 Nm

5 TROUBLESHOOTING

PROBLEM	POSSIBLE CAUSE	SOLUTION
Motor overload	Flow velocity too high	<ul style="list-style-type: none"> Partially close the pressure valve Reduce the rotational speed
	Impeller rubs	<ul style="list-style-type: none"> Reduce the temperature Adjust the distance between the impeller and the tumbler or body
Insufficient flow velocity or pressure	Incorrect direction of rotation of the motor	Reverse the direction of rotation
	Insufficient suction (NPSHa)	<ul style="list-style-type: none"> Increase NPSH available Increase the suction reserve (positive head) Lower the pump Increase the diameter of the suction hose Shorten or make the suction hose direct
	Cavitation	Increase the NPSH available in suction
	The pump sucks in air	Check that the suction hose joints are tight
	Pressure delivered too strong	Reduce thrust by increasing pipe diameter and/or reducing the number of valves or bends
	Liquid temperature too high	Cool the liquid
	Discharge pressure too low	Increase the pressure: install impeller with larger diameter (contact GemmeCotti)
Lack of pressure on the discharge side	Insufficient suction (NPSHa)	<ul style="list-style-type: none"> Increase NPSH availability Increase the suction reserve (positive head) Lower the pump Increase the diameter of the suction hose Shorten or make the suction hose direct
	The pump is clogged	Clean the pump
	The suction hose is blocked	Check valves and filters on the suction line
	Closing the valve on the suction side	Check open the valve
Uneven outlet pressure flow	Incorrect direction of rotation of the motor	<ul style="list-style-type: none"> Reverse the direction of rotation
	Insufficient suction (NPSHa)	<ul style="list-style-type: none"> Increase NPSH availability Increase the suction reserve (positive head) Lower the pump Increase the diameter of the suction hose Shorten or make the suction hose direct
	Cavitation	Increase the NPSH available in suction
	The pump sucks in air	Check that the suction hose joints are tight
	The suction hose is blocked	Check valves and filters on the suction line
	The suction hose is blocked	Check valves and filters on the suction line
Noise and Vibration	Insufficient suction (NPSHa)	<ul style="list-style-type: none"> Increase NPSH availability Increase the suction reserve (positive head) Lower the pump Increase the diameter of the suction hose Shorten or make the suction hose direct
	Cavitation	Increase the NPSH available in suction
	The pump sucks in air	Check that the suction hose joints are tight
	Pressure delivered too strong	Reduce thrust by increasing pipe diameter and/or reducing the number of valves or bends
	Liquid temperature too high	Cool the liquid
	Flow velocity too high	<ul style="list-style-type: none"> Partially close the pressure valve Reduce the rotational speed
	Impeller rubs	<ul style="list-style-type: none"> Reduce the temperature Adjust the distance between the impeller and the tumbler or body
	Foreign objects in the liquid	Cool the liquid

PROBLEM	POSSIBLE CAUSE	SOLUTION
Pump plugged	Liquid temperature too high	Cool the liquid
	Impeller rubs	<ul style="list-style-type: none"> • Reduce the temperature • Adjust the distance between the impeller and the tumbler or body
	Foreign objects in the liquid	Cool the liquid
Pump overheating	Flow velocity too high	<ul style="list-style-type: none"> • Partially close the pressure valve • Reduce the rotational speed
	Liquid temperature too high	Cool the liquid
	Impeller rubs	<ul style="list-style-type: none"> • Reduce the temperature • Adjust the distance between the impeller and the tumbler or body
	Foreign objects in the liquid	Cool the liquid
Abnormal wear	Cavitation	Increase the NPSH available in suction
	The pump sucks in air	Check that the suction hose joints are tight
	Liquid temperature too high	Cool the liquid
	Foreign objects in the liquid	Cool the liquid
Leak in the Pump	Incorrect direction of rotation of the motor	<ul style="list-style-type: none"> • Reverse the direction of rotation
	Incorrect O-ring material for the pumped liquid	Fit an O-ring of a different material (contact GemmeCotti)

6. SPARE PARTS

6.1 How to Order Spares

A complete series of spare parts is available from our warehouse and our distributors. To request spare parts, you must provide the model of your pump, the size, the material, the serial number, the year of construction and the number of the spare part required. These references can be found directly on the pump plate and on the cross-section drawings relating to the pump itself. If you do not have the drawings in the section, contact the GemmeCotti sales office (tel. +39 0296460406).

7. DATA

7.1 Performance curves

HCO pumps made of PP/PVDF thermoplastic material:

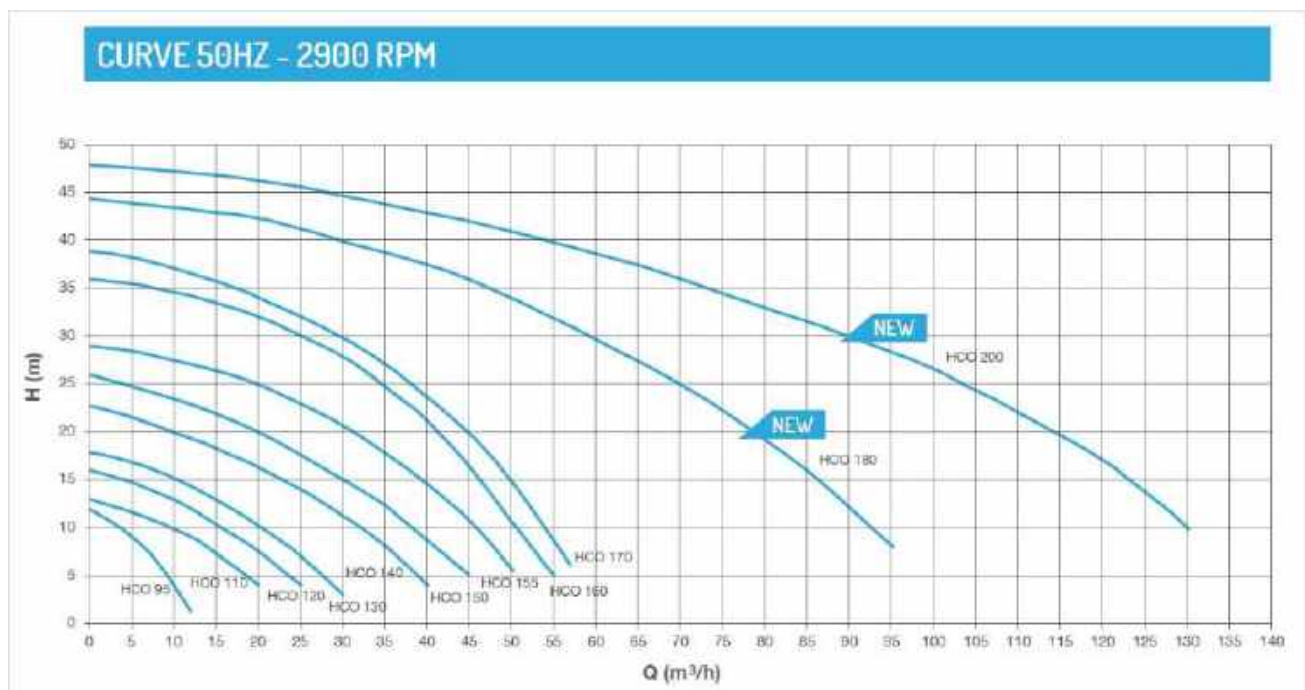

7.2.2 HCO 180 - 200

HCO TECHNICAL DATA

PUMP SIZE	MATERIAL	Q MAX		H MAX		SUCTION CONNECTION	DISCHARGE CONNECTION	PUMP WEIGHT (kg)		SUITABLE MOTOR POWER (kW) 2900 rpm	MOTOR FLANGE AND FRAME
		50Hz (m³/h)	60Hz (USGPM)	50Hz (m/c)	60Hz (ft)			PP	PVDF		
HCO 180	PP-PVDF	95	502	44	208	3" 1/2 MALE	2" 1/2 MALE	13	15	11 - 15 - 18.5 - 22	160MA - 160MB - 160 L - 180 M - B3/B5
HCO 200	PP-PVDF	130	687	48	227	4" MALE	3" 1/2 MALE	13	15	15 - 18.5 - 22 - 37	160MB - 160L - 180M - 200LB - B3/B5

HCO 180 - 200 PP/PVDF

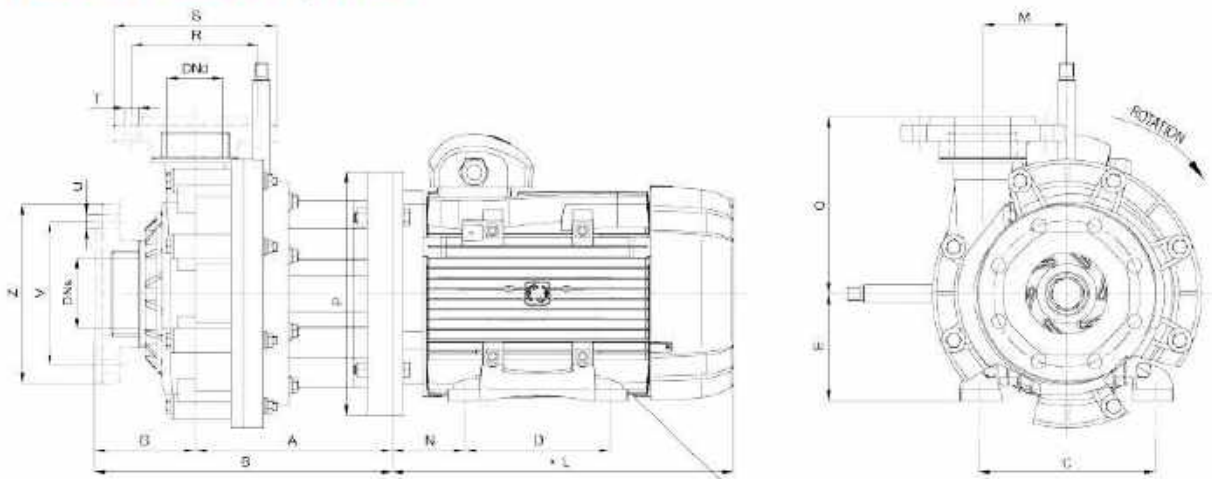

DIMENSIONS - mm -

PUMP TYPE	MOTOR FLANGE B3 - B5	kW	DIMENSIONS - mm -										
			A	B	C	D	E	G	*L	M	N	O	P
HCO 180	160MA	11	272	397	254	280	160	126	555	103	108	215.5	350
	160MB	15	272	397	254	280	160	126	585	103	108	215.5	350
	160 L	18.5	272	397	254	254	160	126	575	103	108	215.5	350
	180 M	22	272	397	279	280	180	126	630	103	121	215.5	350
HCO 200	160MB	15	272	395.5	254	280	160	125	555	103	108	218	350
	160 L	18.5	272	395.5	254	254	160	125	525	103	108	218	350
	180 M	22	272	395.5	279	280	180	125	630	103	121	218	350
	200 LB	37	272	395.5	318	305	200	125	675	103	133	218	400

FLANGES DIMENSIONS - mm -

PUMP TYPE	R	S	T	U	Y	Z	DNs	DNd
HCO 180	145	185	18	18	160	200	80	85
HCO 200	160	200	18	18	180	220	100	80

* Different according to the motor supplier. ** OPTIONAL UPON REQUEST: DIN or ANSI Flanges.
NOTE: DIRECTION OF ROTATION IS COUNTER-CLOCKWISE AS SEEN WHEN FACING THE MOTOR.
PUMPS AVAILABLE THREADED OR FLANGED.

7.4 Technical Data and Limitations

The specific curves are valid for homogeneous fluids with specific gravity = 1, viscosity 1cPs at temperature 20°C. If liquids with a specific gravity greater than 1 are to be pumped, the absorbed power shown on the characteristic curve must be multiplied by the value of the specific gravity of the liquid to be pumped. For liquids with a specific gravity greater than 2, contact the technical service of GemmeCotti s.r.l. (tel. +39 0296460406).

The characteristic curves are valid for homogeneous liquids with a viscosity of 1 CPS. If the pumped liquid has viscosity other than 1 CPS, the Q/H values will be altered. The efficiency of the pump will decrease. For liquids with a viscosity of less than 0.5 CPS or greater than 100 CPS, contact the GemmeCotti technical service.

Values of required NPSH written on the performance curves are the lower required values. As a rule, for safety reasons, the value of NPSH of the system (NPSH available) should be at least 1 m higher than the value of NPSH required (written on the performance curves) to prevent lack of lubrication or dry-running with consequent damage of the bearings.

The available NPSH may decrease as a result of the installation of valves on the intake line. It is advisable to use a flow meter to check for any changes.

The efficiency values shown on the curves refer to sample pumps in the prototyping phase. In pumps built in series, these values may be lower. As a rule, these values should be considered reduced as follows:

- Pumps with discharge connection up to 25 mm: -3 points
- Pumps with a delivery connection greater than 25 mm: -2 points

The characteristics of HCO pumps are guaranteed by the manufacturer with tolerances in accordance with the UNI EN ISO 9906:2002 standards – Hydraulic performance tests and acceptance criteria. Compliance with other specifications or regulations requiring tighter tolerances must be specifically requested at the time of the request for quotation; in this case, the most suitable pump will be selected and the required regulations will be considered accordingly.

8. WARRANTY AND REPAIR

8.1 Warranty

All GemmeCotti products are guaranteed for a period of twelve (12) months starting from the delivery date of the goods.

For the warranty service to be applicable the customer must report the defect in writing no later than 8 (eight) days from the moment that the damage occurs, and must return the part (or parts) to GemmeCotti for repair or replacement. Pumps cannot be repaired or substituted on site. In the case of a request of warranty service, it's better to send the complete pump together with its motor to GemmeCotti.

The costs of delivery and the relative risks, and possible customs duties have to be paid by the customer. GemmeCotti will not accept the costs of collection and shipment.

The manufacturer is not responsible for damages caused during the shipment of the parts or of the pump sent to GemmeCotti to be repaired under warranty.

The warranty system provides that, after a careful examination at our factory, GemmeCotti is free to choose to repair or replace the part (or parts) of the pump which is/are defective in materials or in workmanship, or both. We will not give any refund or credit for the defective material or for direct or indirect damages caused by our pumps. In any case, any reimbursement cannot exceed the cost of the pump or of the supplied material.

If the pumped liquid and the needed performances have not been communicated to GemmeCotti before the offer and confirmed in the quotation and order confirmation and/or the pump is not properly installed, maintained and used for its intended purpose or under conditions which can reasonably be foreseen as indicated in the Machine Directive 2006/42/CE article 4 paragraph 1, the customer takes the whole responsibility for the usage of the product, especially if not used in an appropriate way, and the warranty, the conformity to the Machine Directive 2006/42/CE and the relative CE declaration are no longer valid. The proper installation, maintenance and use for its intended purpose and the conditions which can reasonably be foreseen are subject to the respect of the technical limits (temperature, working point, compatibility of the pump material with the pumped fluid, NPSH etc...) which are indicated in GemmeCotti's technical data files and use and maintenance manuals.

If the above mentioned limits are not respected, the customer is the only responsible for the introduction of the pump in the market, for the declaration of conformity to the Machine Directive and the CE mark. In any case the user is considered the one who knows better the chemical compatibility and the reactions between the liquid to be pumped and the material of construction of the pump and consequently the information given in this regard by GemmeCotti is merely indicative.

If the returned piece is no longer covered by guarantee, or if after inspection GemmeCotti finds the piece to be not defective, inspection charges will be charged to the customer and the repaired or substituted piece will be returned to the customer at the customer's own expense.

Pumps which have been repaired or substituted under guarantee will be supplied on the same delivery conditions as the order and the warranty will not be extended.

Warranty does not cover components subject to natural wear due to time, such as mechanical seals, bearings, bushings and lip seals.

The customer is solely responsible for the good performance of pumps and for their careful maintenance. Therefore no claims will be allowed when goods have been improperly handled (not stored in a suitable closed dry place, which is necessary because of the fragility of materials), contaminated, handled with negligence, improperly installed, tampered with or not well regulated, incorrectly used in wrong applications. In particular, GemmeCotti will not take any responsibility in the case of wear due to corrosion.

Ordinary repairs and/or maintenance must be carried out in accordance with the instructions indicated in the manual and carried out by pumps experts. Any case of pump tampering or modification, the warranty and the CE declaration will lose their validity. In this case, the customer will assume the

product risk and he must issue a new CE declaration of conformity.

The warranty does not cover damages due to extraordinary or natural events, such as lightning, ice, fire and others.

All the warranty obligations are considered fully satisfied after the repair or substitution of the defective parts.

The Warranty service will be suspended in the case of default or delayed payment and the period lost cannot be recovered.

This warranty is an integral part of the offer and of the order confirmation.

In the case of litigation the court which has jurisdiction is the Busto Arsizio (Italy) Tribunal and the law that will be applied is the Italian Law.

8.2 Parts Returns and Repairs

All our distributors have a complete repair service. Contact your local distributor or directly with GemmeCotti srl.

Before returning a pump to our repair services or directly to GemmeCotti the pumps must be reclaimed of the hazardous liquids used. Before returning the pump, the customer must send a declaration of remediation by e-mail or fax as per the facsimile in paragraph 8.3 below.

8.3 Decontamination Declaration (facsimile)⁴

Att.
GemmeCotti S.r.l
Via Po 23/25/27- 20031 Cesate (MI)
Telephone 02. 964. 60. 406
Fax 02. 964. 69. 114

Declaration of Reclamation of Pumps on a subcontracting/repair basis

Ref. DDT repair account n° _____ of _____

Pump Type _____ Serial number _____ Pumped fluid _____

Type of fault encountered _____

In compliance with current safety regulations regarding the protection and safety of operators, the following is declared:

- 1- The pump has been carefully cleaned and decontaminated with a solution suitable for eliminating all traces of operating fluid.
- 2- Residues of washing fluid have been eliminated.
- 3- It is possible to overhaul the pump without any danger to the operators and the environment.

WARNING: Pumps that have not been properly remediated or do not have a declaration of remediation will be rejected and returned to the sender carriage collect.

Date _____

STAMP AND SIGNATURE

⁴ To be completed on the customer's letterhead

8.4 CE Certificate for HCO Series Pumps

Declaration of conformity ⁶ (facsimile)
to the Machinery Directive 2006/42/EC

EC DECLARATION OF CONFORMITY

We declare under our sole responsibility that the pump:

Brand: GEMMECOTTI

Type : Model:

Serial Number:

Year:

As described in the attached documentation, it complies with the Machinery Directive 2006/42 EC (ex 89/392/EEC - 91/368/EEC - 93/44/EEC - 93/68/EEC - 98/37 EEC) only if used with liquids communicated by the customer..... and for the characteristics required of the pump in relation to the order N. of

If the pumped liquid and the required performance have not been communicated, and/or the pump is not used in accordance with its intended purpose or under reasonably foreseeable conditions, the customer assumes full responsibility for the use of the product improperly as specified in the warranty clause Mod. 1.11.4.

Compliance with these requirements is expressed through the marking



ENRICO GEMME
(General Manager)
Cesate, there

Signature

² In cases where the customer does not communicate the type of liquid used in the pump and the expected operating conditions, the EC Declaration of Conformity will not be issued and the customer will assume the responsibility and burden of providing for the Certification of the pump in its application.

8.5 ATEX/CE Certificate for Zone 2 (facsimile)



EU Declaration of conformity

The mechanical seal pump type:

SN

Together with all the pumps series:
EM-CO PP/PVDF
bearing the mark:

CE  II 3G Ex h IIB T6 Gc

models:

EM-CO 95-10 PP/PVDF, EM-CO 110 PP/PVDF, EM-CO 120 PP/PVDF, EM-CO 130 PP/PVDF, EM-CO 140 PP/PVDF, EM-CO 150 PP/PVDF, EM-CO 155 PP/PVDF, EM-CO 160 PP/PVDF, EM-CO 170 PP/PVDF

have been manufactured by GemmeCotti s.r.l. in accordance with the following EC directives:
2014/34/EU (ex 94/9 EC), 2006/42 EC

and the following standards:
EN 12100, EN 13857, EN 809, EN 1127-1, EN 80079-36, EN 80079-37

The manufacturing process is internally controlled by a Quality Management System according to ISO 9001:2015 standards and the internal control of production file n. 101 ext. 01/07, is deposited at CEEI, notified body N.0722.

This declaration of conformity is issued under the sole responsibility of the manufacturer.



ATTENTION: the above magnetic drive pumps, considered as components, comply by design with the directive providing their installation is correctly performed by the manufacturer of the machinery. The pump must not be put on duty until the machinery or plant into which it has been incorporated is declared in conformity with the Machinery Directive. This declaration does not imply any warranty of properties. The safety instruction of the accompanying product documentation shall be observed.

Since there is an endless variety of products and chemical compositions that can be suitable to be processed by the considered devices, the end user is the only responsible to verify the reactions and suitability with materials used to build the pump. Therefore, all necessary tests and checks must be performed with great care to avoid any risk, and any adverse event that cannot be foreseen by the manufacturer and of which the manufacturer cannot be held responsible. Every dispute lies within competence of Varese Court.

Enrico Gemme
General Manager

Cesate, Date: _____



Via Po 23/25/27 – 20031 – Cesate (MI) ITALY – EU

www.gemmecotti.com

Tel. +39 02 96460406 – info@gemmecotti.com

Mod 4.2.11/CEI