



HPP/HPF PUMPS

EM-P PP/PVDF PUMP (ATEX ZONE 2 VERSION)

Thermoplastic mag-drive vane pumps



INSTALLATION, OPERATION AND MAINTENANCE MANUAL

Translation of the original instructions

(SAFETY INSTRUCTIONS)

Index

1. INTRODUCTION	4
1.1 General.....	4
1.2 Purpose of the manual.....	4
1.3 Safety Alert Symbols.....	4
1.4 Qualification and training of the personnel.....	4
1.5 Explosive Atmosphere Zones.....	5
2. INSTALLATION	5
Preliminary remarks.....	5
2.1 Safety general warnings.....	5
2.1.1 Introduction about danger.....	5
2.1.2 Indications of danger.....	5
2.2 Receipt and Inspection.....	6
2.3 Storage.....	7
2.4 Installation and Fixing.....	7
2.5 Hydraulic system.....	7
2.6 Pipes Connection.....	7
2.7 Monitoring equipment.....	8
2.7.1 Control of pump in explosive atmosphere zones ATEX ZONE 2.....	8
2.8 Motor connection.....	9
3. SERVICE	10
3.1 Use and Safety.....	10
3.2 First Start-Up.....	11
3.3 Temperature.....	11
3.4 Before Starting.....	11
3.5 Starting.....	12
3.6 Optimum conditions for use.....	12
3.7 Shut down.....	12
3.8 Long pump inactivity.....	13
3.9 Noise level	13
4. MAINTENANCE	13
4.1 General dispositions.....	13
4.2 Inspections.....	14
4.3 Procedure before disassembly.....	14
4.4 Disassembly.....	15
4.4.1 Main Parts.....	15
4.4.2 Detaching the pump from the motor.....	16
4.4.3 Separation of Pump from Bracket and Internal Magnet Assembly.....	17
4.4.4 Pump Disassembly.....	18
4.5 Reassembling the Pump.....	19

4.5.1 Pre-assembly of the pump casing	19
4.5.2 Rotor and pump casing assembly	20
4.5.3 Final Assembly.....	20
4.6 General Warnings.....	21
4.7 Tightening Torques.....	21
5. PROBLEM SOLUTIONS.....	22
6. SPARE PARTS AND OPTIONALS.....	23
6.1 How to order spare parts and accessories.....	23
6.1.1 Flanges	23
6.1.2 Stands.....	23
6.1.3 Dry-run protection.....	23
6.1.4 Full Range	23
7.DATA.....	24
7.1 Characteristic curves.....	24
7.2 Dimensions	25
7.3 Technical data and limitations.....	26
8. WARRANTY AND REPAIR.....	26
8.1 Warranty.....	26
8.2 Returned parts and repair.....	27
8.3 Decontamination Declaration (facsimile)	28
8.4 CE CERTIFICATE FOR HPP-HPF SERIES PUMPS.....	29
8.5 ATEX/CE Certificate for Zone 2 (facsimile).....	30

1. INTRODUCTION

1.1 General

This manual refers to mag drive vane pumps of HPP/HPF series. Pumps of series HPP/HPF are made of thermoplastic materials (Polypropylene or PVDF) and can be of different sizes. Dimensions and capacities available are described in paragraph 7.0.

1.2 Purpose of the manual

The main purpose of this manual is to assure that the activities of installation, operation and maintenance of the pumps are executed in a correct and safe way by all the personnel in charge of these operations. This document offers also indications useful for the customer to solve the problems, order spare parts and contact GemmeCotti repair service.

ATTENTION: check on our website www.gemmecotti.com if there are further revisions to this manual. You can also find the original instructions written in Italian.

1.3 Safety Alert Symbols



This symbol indicates a possible danger caused by the presence of electrical fields, contacts or wires with electric current.



All the symbols with the exclamation mark indicate an important situation that needs the attention of the personnel. In particular, these are indications useful for the correct functioning and prevention of possible damage to the equipment.



This symbol indicates the presence of strong magnetic fields which can damage or compromise the functioning of other equipment nearby.



This symbol signals a danger or a situation that requires the maximum attention of the personnel. It's important to respect the instructions stated at the margin of this symbol and proceed very carefully. It's necessary to inform all the personnel and/or users that the rules indicated prevent injuries.

1.4 Qualification and training of the personnel



Those in charge of the installation, operation and maintenance of the pumps have to be qualified to carry out the actions indicated in this manual. GemmeCotti is not responsible for the inadequate qualification and training of the customer's staff or for the lack of information of the staff regarding the contents of this manual. It's compulsory to always show this manual to the workers in charge of the installation, operation and maintenance of the pump. Keep this manual in a safe place for future consultations.

1.5 Explosive Atmosphere Zones

The pumps described in this manual CANNOT be used in explosive atmospheres. These uses require special pumps that GemmeCotti manufactures with particular materials and precautions. Customers who want to use special pumps in these kind of zones have to contact the GemmeCotti technical office for the correct choice of the product.

The pumps, manufactured by GemmeCotti, for these kind of applications belong to the series EM-C or EM-T or EM-P.

Pump model EM-C, EM-T e EM-P in PP or PVDF can be used only for Atex zone2, II3G. Please refer to paragraph 2.7.1 for further instructions.



WE REMIND YOU THAT THE CLASSIFICATION OF THE ZONE (REF. ATEX 2014/34/EU FORMER 94/9/CE DIRECTIVE) FOR POTENTIALLY EXPLOSIVE ATMOSPHERE ZONES HAVE TO BE DONE BY THE CUSTOMER AND COMMUNICATED TO GEMMECOTTI FOR THE RIGHT CHOICE OF THE KIND OF PUMP SUITABLE TO WORK IN THESE ZONES.

Furthermore, the customer is responsible of the correct installation of the pump in accordance with the requirements stated in the Directive.

2. INSTALLATION

Preliminary remarks

All the references to the pumps have to be considered applicable also to systems that use these pumps unless it's specified otherwise.

2.1 Safety general warnings¹

2.1.1 Introduction about danger



ATTENTION: the non-observance of the indications stated in this manual or the inappropriate use of the equipment by unqualified or unauthorized staff, can cause serious personal injuries or death and damages to products and apparatus!

The technical assistance office is at the complete disposal; in case of doubts or problems you can contact us by phone (Number +39 02 964.60.406) or write an email to info@gemmecotti.com. It's strongly recommended that you keep GemmeCotti written answer.

2.1.2 Indications of danger



For the safety of those in charge of the installation of the pump it's necessary to use safety clothing and individual safety devices approved by the current provisions of the law (e.g. Safety glass, gloves and safety insulating-shoes)



The pump contains particularly powerful magnets. It's forbidden for those who have cardiac pacemakers, defibrillators, electronic medical devices, metallic heart valves, metallic prosthesis or sickle cell anaemia, to handle or be in the proximity of the magnets contained inside the pumps. Consult a health care provider for specific recommendations before working with these pumps.

¹ If these warnings are not observed the Certification and the Warranty of the pump can be invalidated



The powerful magnetic fields in the proximity of the pumps can damage heart pacemakers, watches, credit cards, discs and magnetic tapes inside calculators and computers.



When working in the proximity of pumps, consider that the devices or metallic parts that you are handling can be unexpectedly attracted towards the pump causing possible crushing of fingers or hands.



These pumps have been designed and manufactured to be used in specific conditions and within defined limits. The use outside these specifications has to be agreed and approved by the GemmeCotti technical service. **It must be considered also that, if the pumps are used outside their technical specifications, the CE Certifications and the warranty are no longer valid. Furthermore, if the pump is used outside the technical specifications communicated to us at the moment of the quotation and confirmed in our order confirmation, the customer becomes responsible for the issue of a new CE Certification.**



The pump has to be used only for the applications specified in the order for which GemmeCotti has selected the model, the materials of construction and has tested the pump to respect the specifications. For other uses different from those stated in the order, the customer has to send always a written request to the GemmeCotti technical office, which on its part will reply in a written form.



There will not be any warranty for repairs or alterations on the product done by the users or third parties not specifically authorized by GemmeCotti.



Always shut down the pump before touching or proceeding with any intervention on it or on the circuit of installation. The pump must be empty of pumped liquid and it must be completely decontaminated and successfully rinsed with water before any manual operations or disassembling.

Make sure that the electrical system to which the pump will be connected has the adequate power and has the correct protection devices (e.g. Grounding, Life safe).



Always switch off the electrical supply before working on the pump for maintenance or part substitution.

Always keep an extinguisher next to the pump installed.



Always pay maximum attention in the execution of maintenance activities on pumps and on the connected circuits when they are used with dangerous liquids.

The use of an electric starter is recommended. A simple switch can be insufficient to start and stop the electric motor connected to the main electric system.

An appropriate starter:

-can prevent accidental starting after a failed attempt to start:

-is a safe switch, protected against water:

-protects the electric motor against overloads due to a short circuit (a fuse protects only the wires);

-resists against starting in overload on the motor, preventing dangerous electric arc and early wear of the electrical contacts.

2.2 Receipt and Inspection

Even if GemmeCotti takes all the necessary precautions during the packaging, we suggest that you carefully check the received material. Check for any missing parts caused by the courier

and/or by GemmeCotti.

Check the data on the label of the received pump and compare it with those relative to your purchase order.

If the pump has been supplied with the motor, remove the protective shield from the fan of the motor and try to rotate the motor shaft by hand. If you feel a strong resistance to rotation or if you hear anomalous noises call your reliable reseller or call the GemmeCotti assistance service directly. Reassemble the protective fan shield before starting the pump.

2.3 Storage



If the pump is placed in storage, make sure that this is done in a non-humid and sheltered location; Always use the original packaging or equivalent protection. If the pump is to be stored for very long periods and/or in particularly humid environments, the use of hygroscopic substances (silica gel) is recommended to prevent damage.



Do not remove the flange protections until the time of installation and if not already closed, plug the holes in the intake/delivery and air connection manifolds to prevent the intrusion of foreign bodies.

It is warned that prolonged storage time of the pumps may result in:

- degradation of the engine insulation due to moisture absorption
- Seal degradation

2.4 Installation and Fixing



GemmeCotti s.r.l. cannot be held responsible for damage to persons or objects caused by improper installation or carried out by unqualified personnel. Install the pump in a location that allows for easy service.



The motor/pump unit must be fixed on a rigid structure that allows the entire structure to be supported. The suction and delivery pipes must not weigh on the nozzles/flanges of the pump. The load of these pipes must be unloaded on special supports positioned just before the delivery and suction of the pump. Make sure that the pump is fixed on a surface, if necessary use the bases supplied by GemmeCotti or shims under the motor support bases. Where deemed necessary, use "bumpers" to reduce vibrations towards the fixing surface.

2.5 Hydraulic system



The pump is generally part of a hydraulic system that can include a various number of components such as, valves, fittings, filters, expansion joints, instruments, etc. The way the piping is arranged and the position of the components has a great influence on the operation and on the life of the pump.

It is advisable to wash the new systems internally before installing the pump to remove any processing residues to prevent them from entering it and damaging it.

2.6 Pipes Connection ²

Locate the pump as near as possible to the liquid source and below the level of the liquid (under the head).

Always use pipes as short and straight as possible and limit the number of bends assuring radius of curvature as large as possible. Avoid air siphon that can be created in the long piping

² Failure to follow the warnings provided may void the warranty terms on the pumps supplied.

line. Avoid the creation of siphon also before the suction of the pump.



The piping should be properly supported and kept in line independently from the pump, until its connections, so that the piping doesn't exert loads on the pump.



The sizes of the suction and discharge pipes have to be at least as large as the inlet connection of the pump. Diameter restriction of the suction pipe is responsible and cause of the cavitation of the pump, creating a loss in the performance of the pump and a rapid wear. It's advisable always to use (if in case) flexible reinforced pipes that don't collapse under a situation of depression.



The suction line has to be clean and/or contain a filter to protect the impeller from damage due to impurities, or other foreign particles, especially when starting the plant for the first time.

Don't use metallic piping with plastic pumps.

Don't use tools to connect piping to plastic pumps. Make sure that the connections are properly tightened otherwise the suction capacity will be reduced.



The installation of a proper pressure gauge on both the suction and discharge piping is recommended. The installation of gauges allows an easy control of the correct functioning of the pump in relation with the required working point. In case of cavitation or other dysfunctions, the gauges will show evident pressure fluctuations.

2.7 Monitoring equipment

According to the importance of the pumping system, it could be useful to maintain a strict control of the performances and conditions of the process. The use of instruments to monitor the pressure of the suction and discharge circuit is recommended.

Even the monitoring of the electric power absorbed by the motor is possible using a wattmeter.



If the temperature of the pumped liquid represents a critical element install in the system a thermometer, preferably on suction line.

These control instruments can advise of abnormal operating conditions of pumps such as: accidentally closed valves, missing liquid, overloads etc.

2.7.1 Control of pump in explosive atmosphere zones ATEX ZONE 2

In addition to complying with the general warnings specified in this manual, special pumps to be used in potentially explosive environments must be installed with the control devices specified in this paragraph in order to maintain close monitoring of process performance and condition. Control devices mounted in the vicinity of the pump shall be certified for the same hazardous area identified for the installation of the pump unless they are protected by watertight cabinets which are themselves certified.

To avoid overloads on the pumps due to impurities or solid particles in the pumped liquid, the use of a filter in the suction line is strongly recommended. This filter has to be regularly checked to avoid obstruction.

The installation of pumps of type EM-(C-T-P) for use in potentially explosive environments must comply with the rules of the ATEX Directive 2014/34/EU.

In particular, the manufacturer's requirements applicable to **Category 3 of Group II** appliances (explosive atmosphere due to the presence of gases, vapors or mists) are as follows:

- Appliances must be designed and constructed in such a way as to avoid ignition sources that can be expected during normal operation.
- Under the intended operating conditions, surface temperatures shall not exceed the maximum design temperatures stated (paragraph 3.1). Any exceedance is tolerable, in exceptional cases, if the manufacturer takes additional special protective measures.

The temperature classes are defined as per the table:

Temperature class according to ISO80079-36	Temperature limit of the liquid
T6 (85°C)	60°C
T5 (100°C)	75°C
T4 (135°C)	110°C
T3 (200°C)	175°C

- The ambient temperature must be between -20°C and 40°C as per ISO 80079-36
- The temperature of the fluid must be monitored in suction.
- Warning: the table with the temperature ranges is valid only in optimal conditions of use of the pumps (rpm, flow rate, head and NPSHa) of correct lubrication and maintenance.
- In any case, the fluid temperature must not exceed the pump's maximum or minimum design temperature (see section 3.1)



It is not recommended to mount the suction filter to avoid obstruction to the suction of the pump which can cause cavitation and/or dry running. A suction filter can only be useful during the start-up phase, for cleaning the same and in any case it must be monitored to avoid clogging that would lead to the correct operation of the pump.



If unacceptable working conditions are detected, the pump must be stopped automatically and overhauled.



NPSHa may decrease as a result of the installation of a valve or bends, filters, elbows on the suction line, in this case it is necessary to install a flow meter to check for any variations.



The pump is supplied with a metal front ring and therefore with an accurate ground connection of the same there can be no unwanted electrostatic charges as a source of ignition for explosions.



The pump installed in ATEX zone 2 must be coupled to a suitable explosion-proof motor.

2.8 Motor connection

Check that the tension and frequency printed on the label of the motor correspond to those of the electric system to be used.



Don't connect the electric motor directly to the main system but protect the dedicated system with a suitable main switch with adequate safety protections against overloads.

The electric connections have to be always carried out by an expert qualified electrician.



The motors have to be supplied with three-phase tensions or if required by the customer, with mono phase tension. The type of connection of the three-phase motors can be Star (Y) or Delta (Δ) according with the power supply 380 or 220 VAC (see picture 1).

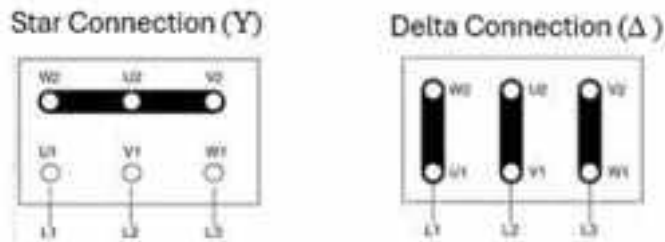

Picture 1



Make sure that the sense of rotation of the motor is that specified on the pump head and eventually indicated by a sticker arrow on the motor fan; to change the sense of rotation it's sufficient to change two of the three entering line (E.g. L1 with L2) in three-phase motors.

Read the following instructions to change the sense of rotation:

- wear individual homologated protection devices (e.g. Gloves, glasses)
- make sure that the operating conditions are analogous to the specifications of the pump (see paragraph 7)
- install the pump in the hydraulic system
- open the suction and the discharge valve completely;
- fill the pump with the liquid. It's recommended to perform this test with an inert liquid like water
- do not run the pump dry (Note: the design of mag drive pumps don't allow dry running because it causes damages to the inner components of the pump)
- start the motor only for one or two seconds to check that the sense of rotation is in the same direction of the arrow on the pump head or on the motor and on the technical drawing of the pump (the sense of rotation is clockwise looking at the front of the pump and counterclockwise looking at the motor fan).



NOTE: a pump turning backwards will pump but at a greatly reduced capacity and pressure

3. SERVICE

3.1 Use and Safety

ATTENTION:

Dangerous or hazardous actions can cause serious injuries or death to people or serious damage to materials and so it's important to assure the respect of all the warnings relative to the safety and the correct use written in this manual.



Verify always that the pumped liquid is compatible with the materials of construction of the pump. For any clarification please contact GemmeCotti technical office.



In case of use for pumping aggressive, toxic liquids or liquids dangerous for the health of the personnel, it's necessary to install on the pump an adequate protection for the containment, the collection and the warning of any dangerous product in case of leakage: e.g. DANGER OF POLLUTION, CONTAMINATION, INJURIES AND/OR DEATH

Do not pump liquids containing solids in suspension. Mag drive pumps are designed to pump



clean liquids. The use of a suction strainer is strongly recommended (however the filter has to be kept clean). We suggest a continuous check of the suction strainer to avoid obstruction of the suction causing cavitation. Avoid in particular to pumping liquids containing ferro oxides or other ferromagnetic particles, even if small. If you are in doubt, please call GemmeCotti technical service (tel. +390296460406).



Do not reduce the suction. Reduction of the suction is responsible of the cavitation of the pump, which causes a loss of efficiency and a rapid wear. Reduction of the discharge are not advisable, if required, reduction of the capacity can be obtained by means of a valve installed on the discharge pipe.



Do not loosen the connection of the pump while it's under pressure.



Do not start and/or use the pump if there are signs of leak in the system.

The working temperatures have to respect the characteristics of the construction materials of the pump:

- 0-60 °C polypropylene execution (PP)
- 0- 80° C PVDF execution



DO NOT ALLOW THE PUMP TO RUN DRY FOR MORE THAN FEW SECONDS (note: the mag drive pump design doesn't allow the dry-running functioning because it will damage irrevocably the inner parts of the pump)

IN ADDITION



- An accidental failure can generate splashes up to a considerable distance.
- In case of vibrations or abnormal noises, stop the pump immediately.
- Do not pump flaming liquids.
- Do not touch the pump while it is running.
- Before touching the motor or the bracket, turn off the power.

3.2 First Start-Up



Fill the pump with water or with the liquid to be pumped before starting the unit. This will protect the bearings and the shaft of the pump against dry running. **DO NOT ALLOW THE PUMP TO RUN DRY** because this can cause serious damages to the internal parts of the pump due to the lack of the necessary lubrication.

3.3 Temperature



Increasing the temperature of the pumped liquid can damage the pump and/or the piping/fittings and there can be a situation of serious danger for the people in the nearby.

Avoid sudden changes in temperature and do not exceed the temperatures specified in the order. See the temperature values of the pump construction materials in section 3.1.

3.4 Before Starting

Make sure that the pump is installed in accordance with the instructions supplied in the previous section 2.



When the pumping station is new, it's necessary to fill the system with water to control that there are no leaks. **WHEN THE PUMP IS INSTALLED OVER HEAD IT HAS TO BE PRIMED, THIS MEANS THAT IT HAS TO BE FILLED WITH THE LIQUID AND THE SUCTION PIPING HAS TO BE KEPT FULL OF LIQUID BEFORE STARTING THE PUMP.**



ATTENTION: some liquids react with water. **VERIFY IF THE LIQUID TO BE PUMPED REACTS WITH WATER. IN THIS CASE THE SYSTEM HAS TO BE COMPLETELY EMPTIED AND DRIED.**

3.5 Starting



Start the electric motor and make sure that all the valves on the discharge line are completely open in order to avoid a sudden increase of pressure.



The pump cannot operate with the discharge closed because it can cause serious damage to the pump.

If the pressure shown on the pressure gauge on the discharge piping does not increase, stop the pump immediately and release the pressure carefully.

Repeat the operation of installation of the pump as in paragraph 2.

If during the starting procedure there are changes of flow-rate, of density, temperature or viscosity of the liquid, stop the pump and contact GemmeCotti technical service.

3.6 Optimum conditions for use

Operating continuously at the maximum performances (maximum capacity/head) there can be an early wear of the pump. As a general rule, we recommend using the pump at half of its maximum capacity (see the paragraph relative to the technical data)



The capacity and the head of the pump refer to water pumping at room temperature. If it pumps high temperature liquids or other viscosities and densities, the performances have to be proportionately decreased. Pumps of series HPP/HPF work well with liquids having a viscosity up to 100 CPS³ and specific gravity up to 1.9³. **HOWEVER BOTH THE VISCOSITY AND THE SPECIFIC GRAVITY HAVE TO BE COMMUNICATED AT THE MOMENT OF QUOTATION.** The electric motor is selected for the viscosity and the specific gravity communicated. In the case of higher values, the power of the motor could be insufficient.

3.7 Shut down

Normally the pump should be shut down only after closing the discharge valve. If the suction valve is closed before the other, cavitation of the pump can occur.

If the suction is flooded, close the valve after shutting down the pump.



In some cases the pump can be used to empty tanks, in these situations the liquid can stop flowing in the pump while this is still working. In these cases a pump operating without liquids (that means dry-running) can be dangerously damaged if it's not stopped immediately. For

³ The values indicated are merely indicative and can vary in the series of pumps mod. HTM

such applications the use of automatic equipment or the constant presence of a person who can shut down the pump is recommended.

3.8 8 Long pump inactivity



If the pump has to remain inactive for a long period, before stopping it, it's recommended to let water flow in the system for several minutes so that you avoid any risk of internal deposits or sediments or precipitations of solid parts. Drain the liquid in the pump. An eventual freezing of the liquid inside the pump can cause damage. Always verify if the pumped liquid reacts with water. In this case contact GemmeCotti to find an alternative solution.

If the pump is temporary removed from the system and kept in stock, it's necessary to follow the instructions of paragraph 2.3 "Storage".

3.9 Noise level

In some circumstances, for example when the pump works with high pressure and low capacity the noise increases and can be disturbing for the personnel working in the proximity. In this case it's possible to intervene with:



- earplugs;
- protective homologated caps against noises for the personnel in the proximity;
- soundproofing canopy for the pump. In these cases make sure that the motor ventilation is guaranteed.

4. MAINTENANCE

4.1 General dispositions



During the warranty period extraordinary maintenance is allowed only for GemmeCotti personnel or personnel authorized by GemmeCotti. All the operations described in the paragraphs below have to be done exclusively by qualified staff and following step by step all the warnings written in this manual.

In case of ordinary maintenance (as indicated in paragraph 4.2) the customer is responsible for the correct assembly and disassembly of the pump. The warranty is no more valid if the pump is manipulated/sabotaged, the parts used for the maintenance are not GemmeCotti original or in case of operations not in compliance with the instructions indicated in this manual.

During ordinary maintenance the customer should check the absence of leakage (through hydrostatic tests, paying attention to respect the NP of the pump.), the magnet/impeller alignment, the correct shaft positioning, the correct bearing placement and the right functioning of the pump. For the tightening torque of the screws please refer to paragraph 4.7. Pay attention also to avoid ruining the o-ring when mounting it.



Clean the external surface of the pumps using only antistatic equipment. Every operation executed on the apparatus has to be done after the disconnection of electric supply.



Use exclusively a goods lift to move pumps with weight higher than 16 kg. During the movements of the machine or parts of the machine avoid collisions or falls which can damage the apparatus.



Before disassembling the parts of the pump, make sure that the dangerous internal liquids have

been removed /washed. **THE PUMP HAS TO BE DRAINED AND DECONTAMINATED.**



Pay attention that some internal liquids can have dangerous reactions in contact with water.



During the operations of unloading of dangerous liquids make sure that situations of danger for people or environment don't occur.

4.2 Inspections

In general mag drive pumps do not need a “routine” maintenance and most of all they don't require frequent dismantling.

However periodical inspections are advisable to verify the state of wear of the rotor, the vanes, the o-rings and the bearings and if the general conditions of the internal parts of the pump are good.

The time between the inspections is strongly dependent on the operation conditions of the pump: the characteristics of the liquid, the temperature, the materials used and obviously the period of operation.

After the first start-up of the pump we strongly recommend an inspection of the bearings and the vanes after 3 months of functioning. If the inspection has positive results, we recommend a second check after further 6 months. The following inspection can be scheduled after another year of functioning (about 2000 working hours of the pump). In any case it is advisable to replace the bearings in PTFEC and the vanes every 2000 hours of functioning of the pump. All the other components can be replaced only when they show signs of wear.

If a problem occurred or the pump needs a complete inspection see section “Problem solutions” and “Pump disassembly”.

4.3 Procedure before disassembly



ATTENTION:

If the pump has pumped hot liquids, make sure that it's been cooled before the disassembly procedure. It's possible that the pump has pumped toxic and/or dangerous liquids: so it's necessary to wear protection for the skin and the eyes



ATTENTION:

Make sure that the pump has been carefully decontaminated and cleaned. Wash and neutralize completely the dangerous liquids inside the pump. The liquid has to be collected and eliminated according to the existing environmental laws. After disconnecting the discharge and suction pipes close the extremities.



ATTENTION:

GemmeCotti pumps contain extremely strong magnets. The use of non ferromagnetic tools and working surfaces is highly recommended.

Pay attention to the strong magnetic attraction when disassembling/assembling the unit motor-external magnet of the pump.

The area in which maintenance is done has to be clean and without ferric particles that can be attracted by the magnets.



ATTENTION:

Wearers of PACE MAKER or equivalent devices cannot operate on or near the pump due to the presence of strong magnetic fields.



ATTENTION:

It is recommended not to work in the vicinity of magnets when wearing ferromagnetic wristwatches, bracelets, rings and jewellery and/or with electronic equipment sensitive to magnetic fields.

4.4 Disassembly

NOTE: the photos used to show the operations of disassembly refer to a particular pump model of the series HPP/HPF and consequently the pump supplied to you can be slightly different from what is shown.

4.4.1 Main Parts

Figure 1 shows the main parts of a pump series HPP/HPF in thermoplastic material.

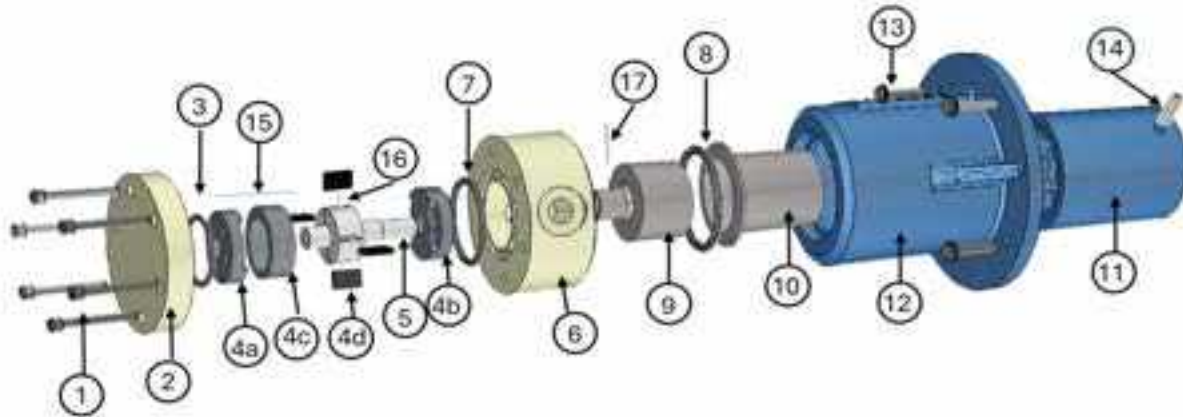

Position	1	2	3	4a	4b	4c	4d	5	6
Part Descr	Allen screw	End Cover	O-ring	Upper Flange	Lower Flange	Stator	Vanes	Rotor Shaft	Pump Body
Material	Aisi 304	PP PVDF	Edpm-Viton	Graphite + PVDF	Graphite + PVDF	Graphite + PVDF	Graphite + PVDF	PVDF	PP PVDF
Position	7	8	9	10	11	12	13	14	15/16/17
Part Descr	O-ring	O-ring	Internal Magnet	Rear Casing	External Magnet	Bracket	Set Screw	Allen Screw	Pins
Material	Edpm-Viton	Edpm-Viton	PP PVDF	PP PVDF	C40 + NdFeb	Aluminium	Aisi 304	Aisi 316	PVDF

Figure 1

4.4.2 Detaching the pump from the motor

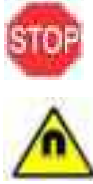

1. After removing the 4 screws tightening the pump to the motor (13), separate the parts, **taking particular care** as the adhesive force of the two magnetic elements (Internal Magnet Assembly in the pump and External Magnet Assembly on the motor shaft) during separation could cause the operator's fingers to be crushed.

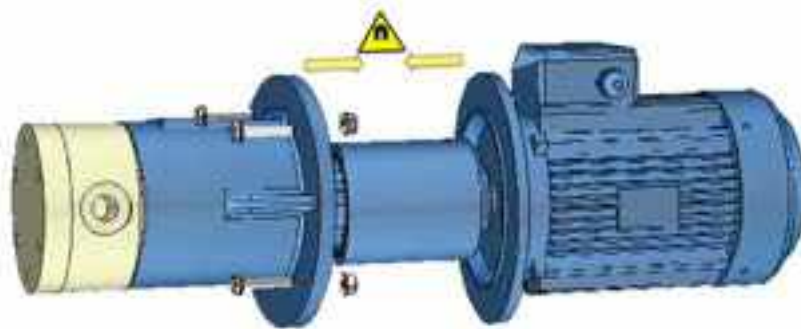

Figure 2

2. If it is necessary to remove the external magnet (Figure 3) from the motor shaft, proceed unscrewing the two grub screws with an Allen key and then use a puller to avoid damage to the motor shaft or the external magnet

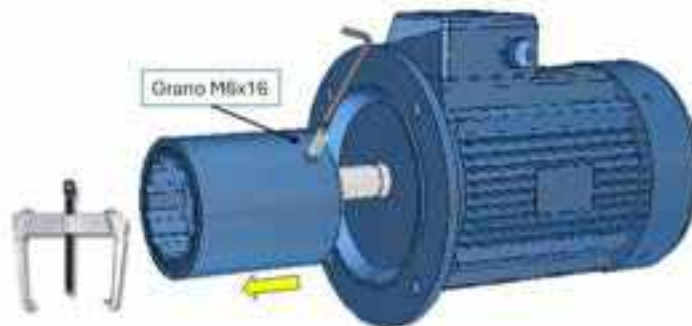

Figure 3

4.4.3 Separation of Pump from Bracket and Internal Magnet Assembly



Every time a pump is used and then disassembled, you should substitute the O-rings (pos 3-7-8 Figure 1) and proceed according to the recommendations written in this paragraph.

1. Disassemble the pump by removing the screws (1) using an Allen key, removing the cover (2) from the bracket (12), freeing the rear casing (10) and the O-rings (3) and (8) that will be replaced. See figure 4

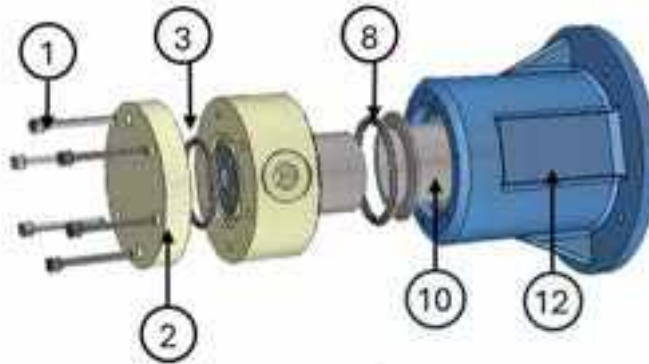

Figure 4

2. Identify the hole in the Internal Magnet Assembly where the pin (17) is housed (Figure 5 a), and remove it with a Pin Punch and hammer (Figure 5b) supporting the assembly adequately so as not to damage the parts
3. Detach the Internal Magnet Assembly from the pump assembly using an extractor if possible (Figure 5c).
4. The Pump assembly, the Internal Magnet Assembly, the plug (17) and the O-ring (7) are obtained (Figure 5d)

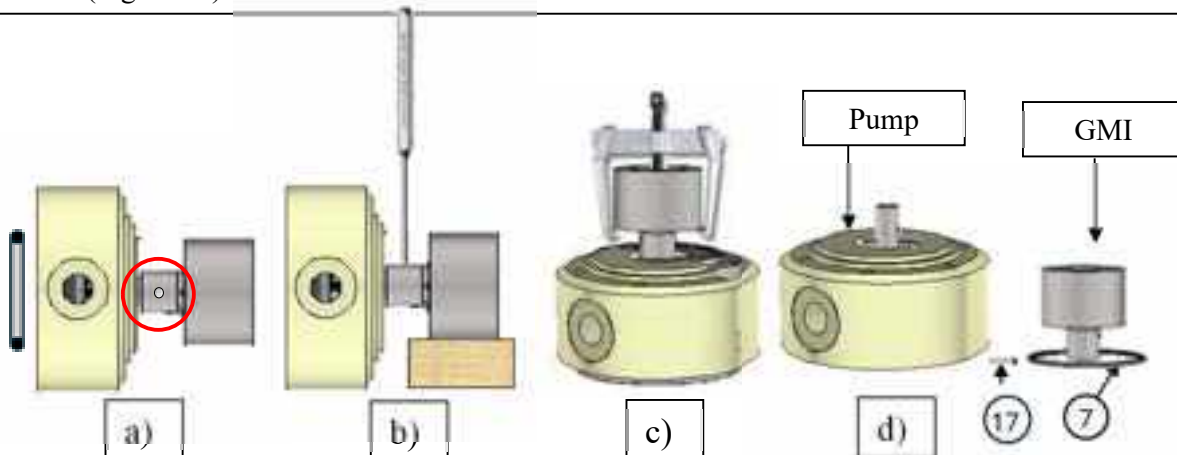
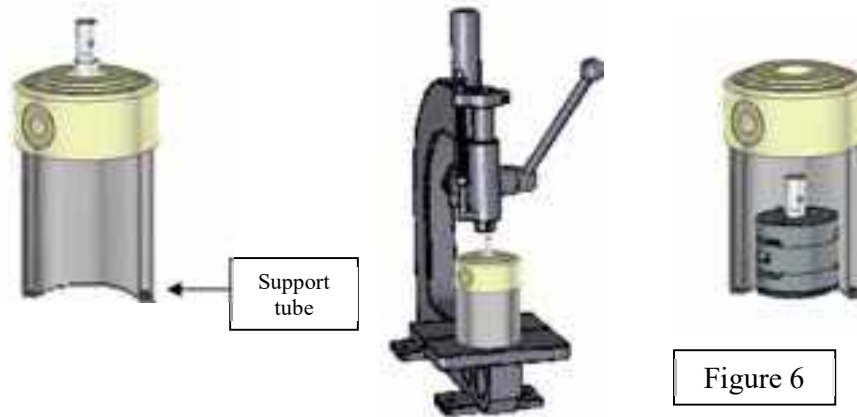

Figure 5

4.4.4 Pump Disassembly

- Due to slight interference, to remove the stator flanges (4) and the rotor (5) with the vanes from the pump body, place the block under a hand press and support it with a pipe of suitable diameter



- By disassembling the stator flanges and the rotor, the parts shown in Figure 7 will be obtained. In the versions of Range 2 the rotor shaft (5) is longer and protruding outside the inner magnet (10), so it is also inserted into the bushing of the bottom of the socket (10)

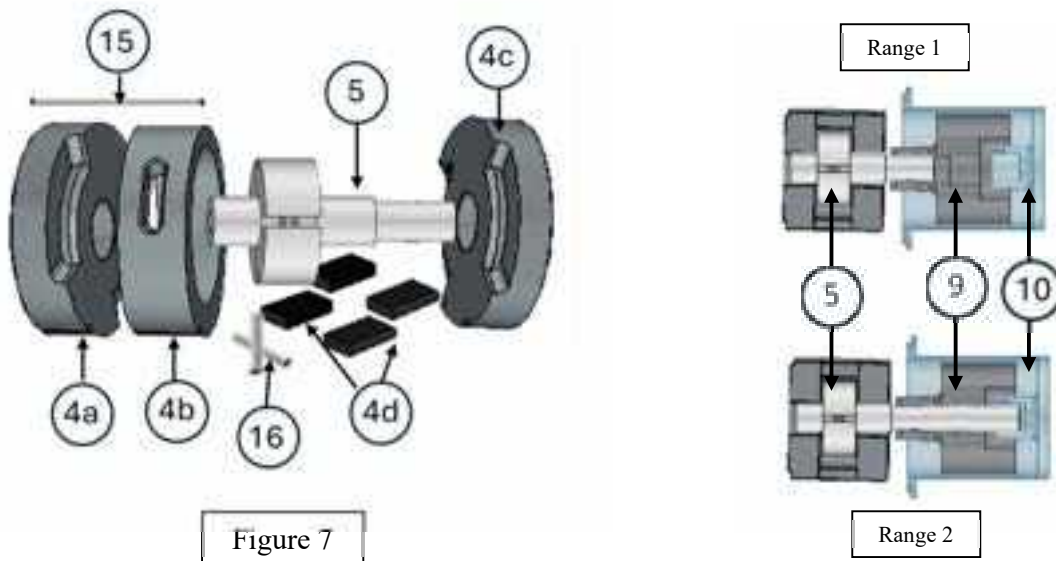

- Clean and inspect all parts by replacing any damaged or particularly worn components; Always replace the O-rings in the assembly.

4.5 Reassembling the Pump

4.5.1 Pre-assembly of the pump casing



WARNING: Clean each component thoroughly before assembly, make sure all parts are free of dirt, metal particles etc

- 1- Identify, in the pump body, the hole shown in Figure 8, which will be the housing of the plug (15) but which will first be used to insert a metal rod that will act as a guide for the housing of the subsequent components. Then use a hand press and a sleeve suitable for mounting with slight interference of the flanges (Fig. 9)



Figure 8



Figure 9

- 2- Insert a metal rod into the hole identified in Figure 8, on the bottom of the pump casing, to act as a guide for inserting the graphite bushings (4b)(4c) (Figure 10).
NB. Do not confuse the lower flange (4b) with the upper flange (4a), which, if retrofitted, has the rebate for the housing of the O-ring (3). For flange orientation, refer to figure 7
- 3- Remove the metal rod and insert the pin (15) as far as it will go (Figure 11)

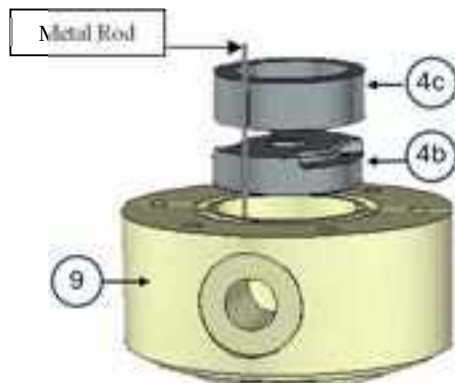

Figure 10

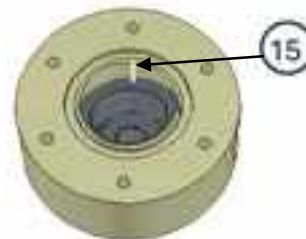

Figure 11

4.5.2 Rotor and pump casing assembly

- 4- Insert the two pins (16) into the holes placed at 90° on the rotor (5) (Figure 12).
 5- Then insert the rotor (5) into the pump housing (Figure 13) that was previously assembled.

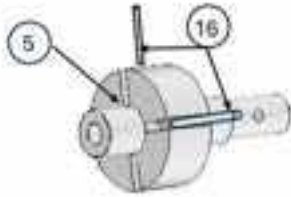

Figure 12

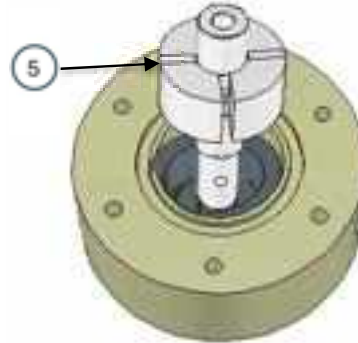

Figure 13a

- 6- Position the four graphite vanes (4d) in the rotor millings (Figure 13b); then insert the graphite front disc (4a) with the O-ring seat facing outward (Figure 13c), then place the O-rings (3) and (7).

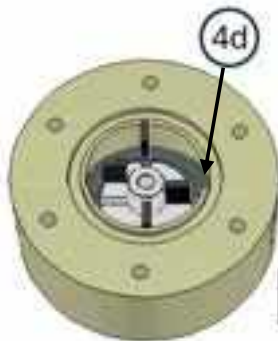

Figure 13b

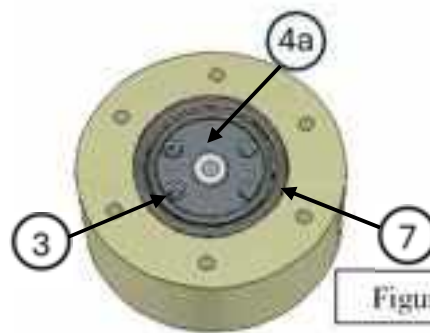

Figure 13c

4.5.3 Final Assembly

The assembly sequences are mirrored to the disassembly sequence described in paragraph 4.4.3. Briefly:

- 7- Fit the Internal Magnet Assembly into the rotor shaft and insert the plug. (refer to Fig.5)
 8- Fit the pump body (8) and the rear casing (10) and lock everything by screwing the cover (2) onto the bracket (12) using the screws (1) (refer to Fig.4)
 9- Reassemble the engine, following the instructions and warnings given in point 4.4.2



WARNING: *In the case of motor replacement, make sure that the characteristics of the motor to be mounted are the same as the motor being replaced. The manufacturer of the engine may be different from the one previously fitted.*

4.6 General Warnings



- always check that the flanges are correctly seated and if necessary use a manual press for their complete insertion into place;



- Make sure that when the pump is closed, the O-rings are perfectly in place and are not pinched.



- during the introduction of the pump on the motor pay attention to the magnetic attraction that can cause injury to fingers or hands;



- use dynamometric wrench for the correct strength to tighten the bolts in accordance with the chart of the following section 4.7.



- after assembling the pump on the motor flange, remove temporarily the protective shield on the fan at the back of the motor and rotate it by hand to check the free rotation of the unite. In case of excessive friction or anomalous noises, disassemble the group (instructions paragraph 4.4) and find out the cause of the problem. Never use the pump without proceeding with this test. Reassemble the fan protective shield before starting the pump. Do not start the pump if the fan protective shield is not installed.

4.7 Tightening Torques

The recommended tightening torques are shown in the table below:

THREAD	COUPLING TYPE	
	PLASTIC / PLASTICPLASTIC / METAL	METAL / METAL
M5	3 Nm	8 Nm
M6	6 Nm	13 Nm
M8	10 Nm	32 Nm
M10	17 Nm	65 Nm
M12	25 Nm	110 Nm
M16	50 Nm	290 Nm

6. SPARE PARTS AND OPTIONALS

6.1 How to order spare parts and accessories

A complete series of spare parts and accessories is available from our warehouse and our distributors. To request spare parts, you must provide the model of your pump, the size, the material, the serial number, the year of construction and the number of the spare part required. These references can be found directly on the pump plate and on the cross-section drawings relating to the pump itself. If you do not have the drawings in the section, contact the GemmeCotti sales office (tel. +39 0296460406).



6.1.1. Flanges

On request, GemmeCotti supplies DIN and ANSI flanges for plastic pumps (flat stub + slip-on flange) and DIN or ANSI welded flanges for AISI 316 pumps.



6.1.2. Stands

GemmeCotti crankcases are suitable for pumps complete with motor with B3/B5 configuration. They allow the pump to be positioned correctly.



6.1.3. Dry-run protection

We recommend the use of the A1-13Y device against dry running for all applications where the constant presence of liquid in the pump is not ensured.



6.1.4 Full Range

Use the QR code for a complete view of the range of available accessories

7.DATA

7.1 Characteristic curves

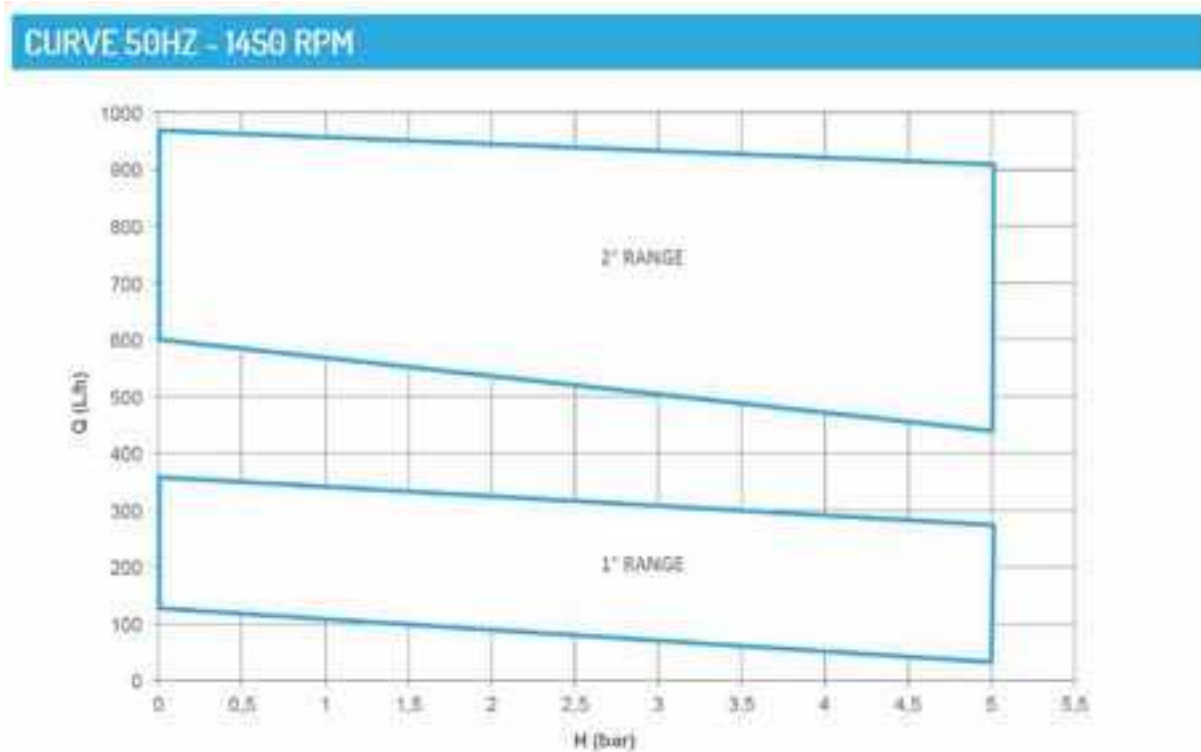

POMPA	MATERIALE POMPA	DIM. IN		DIM. OUT		CONNESSIONE	MATERIALE	POTENZA IN W		MATERIALE CONDIZIONE	RANGE
		Ø (mm)	Ø (mm)	Ø (mm)	Ø (mm)			IN	OUT		
HP100-100-10	PP-PVC	100	100	5	72	1/2" FEMMINA	3/8" FEMMINA	2,9	3,2	0,27	75-102/95
HP100-150-10	PP-PVC	200	150	5	72	3/8" FEMMINA	3/8" FEMMINA	2,9	3,2	0,27	75-102/95
HP100-200-10	PP-PVC	200	150	5	72	1/2" FEMMINA	3/8" FEMMINA	2,9	3,2	0,27	75-102/95
HP100-300-10	PP-PVC	300	150	5	72	3/8" FEMMINA	3/8" FEMMINA	2,9	3,2	0,27	75-102/95
HP100-400-10	PP-PVC	400	200	5	72	1/2" FEMMINA	1/2" FEMMINA	7	7,5	1,0	90-102/95
HP100-500-10	PP-PVC	500	200	5	72	3/4" FEMMINA	1/2" FEMMINA	7	7,5	1,0	90-102/95
HP100-600-10	PP-PVC	600	200	5	72	1" FEMMINA	1/2" FEMMINA	7	7,5	1,0	90-102/95

For more details check our website www.gemmecotti.com

7.2 Dimensions

HPP-HPF 1° RANGE DIMENSIONI

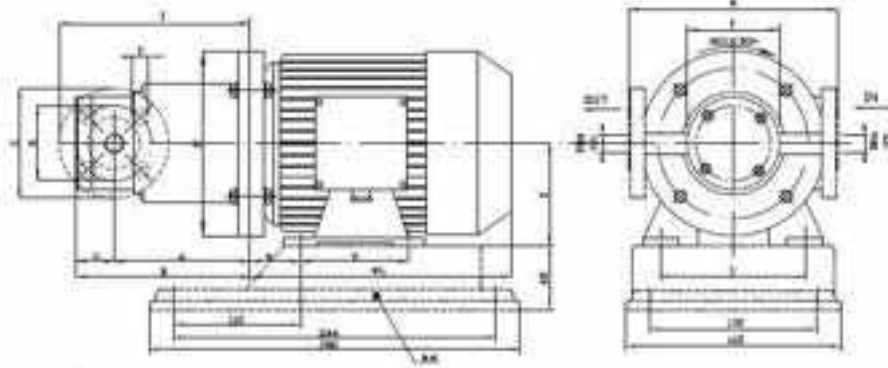

HPP-HPF 2° RANGE DIMENSIONI

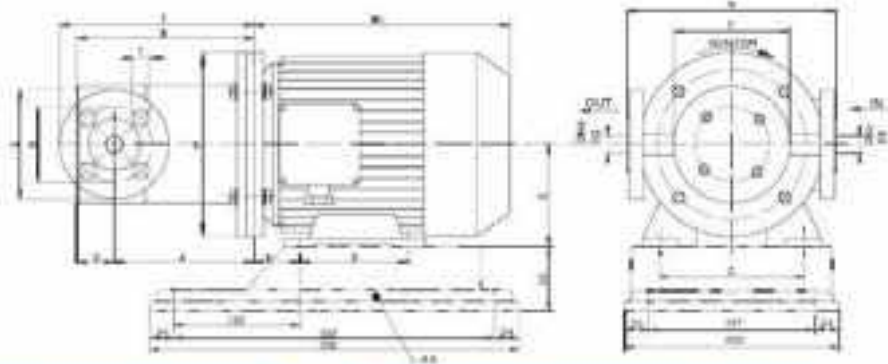

FORMA	DIMENSIONI FLANGIA - mm - DN 10 PN 10				
	B	S	T	DN _h	DN _d
HPP-HPF 1° RANGE	65	95	14	5	5

FORMA	DIMENSIONI FLANGIA - mm - DN 20 PN 10				
	B	S	T	DN _h	DN _d
HPP-HPF 2° RANGE	75	105	14	20	20

FORMA	FLANGIA MOTORE ED-80	P _W	DIMENSIONI - mm -													
			A	B	C	D	E	F	G	I	L	M	N	O	P	Q
HPP-HPF 1° RANGE	75-48	0,37	128	164	82	80	71	80	39	65	26	82	45	3/8"	100	3/8"
HPP-HPF 2° RANGE	88-52	1,5	168	203	140	100	90	127	44	112	35	108	58	1/2"	100	1/2"

* Diverso a seconda del fornitore di motori. ** OPTIONAL A RICHIESTA: Basamento e flange

7.3 Technical data and limitations

The specific curves are valid for homogeneous fluids with specific gravity = 1. If liquids with a specific gravity greater than 1 are to be pumped, the absorbed power shown on the characteristic curve must be multiplied by the value of the specific gravity of the liquid to be pumped. For liquids with a specific gravity greater than 2, please contact the technical service of GemmeCotti s.r.l. (tel. +390296460406; e-mail info@gemmecotti.com).

The characteristic curves are valid for homogeneous liquids with a viscosity of 1 CPS. If the pumped liquid has viscosity other than 1 CPS, the Q/H values will be altered. The efficiency of the pump will decrease. For liquids with a viscosity of less than 0.5 CPS or greater than 150 CPS, please contact the GemmeCotti technical service.

The required NPSH values shown on the characteristic curves are the lowest required values. As a rule, for safety reasons, the NPSHa value of the system (available NPSH) must be at least 1 m higher than the required NPSHa value (shown on the characteristic curves) to avoid problems due to lack of lubrication or dry running with consequent damage to the bushings. The available NPSH may decrease as a result of the installation of curved valves/elbows/filters etc on the intake line. It is advisable to use a flow meter to check for any changes.

The efficiency values shown on the curves refer to sample pumps in the prototyping phase. In pumps built in series, these values may be lower. As a rule, these values should be considered reduced as follows:

- Pumps with discharge connection up to 25 mm: -3 points
- Pumps with a delivery connection greater than 25 mm: -2 points

The characteristics of HPP-HPF pumps are guaranteed by the manufacturer with tolerances in accordance with the UNI EN ISO 9906:2002 standards – Hydraulic performance tests and acceptance criteria. Compliance with other specifications or regulations requiring tighter tolerances must be specifically requested at the time of the request for quotation; in this case, the most suitable pump will be selected and the required regulations will be considered accordingly.

8. WARRANTY AND REPAIR

8.1 Warranty

All GemmeCotti products are guaranteed for a period of twelve (12) months starting from the delivery date of the goods.

For the warranty service to be applicable the customer must report the defect in writing no later than 8 (eight) days from the moment that the damage occurs, and must return the part (or parts) to GemmeCotti for repair or replacement. Pumps cannot be repaired or substituted on site. In the case of a request of warranty service, it's better to send the complete pump together with its motor to GemmeCotti.

The costs of delivery and the relative risks, and possible customs duties have to be paid by the customer. GemmeCotti will not accept the costs of collection and shipment.

The manufacturer is not responsible for damages caused during the shipment of the parts or of the pump sent to GemmeCotti to be repaired under warranty.

The warranty system provides that, after a careful examination at our factory, GemmeCotti is free to choose to repair or replace the part (or parts) of the pump which is/are defective in materials or in workmanship, or both. We will not give any refund or credit for the defective material or for direct or indirect damages caused by our pumps. In any case, any

reimbursement cannot exceed the cost of the pump or of the supplied material.

If the pumped liquid and the needed performances have not been communicated to GemmeCotti before the offer and confirmed in the quotation and order confirmation and/or the pump is not properly installed, maintained and used for its intended purpose or under conditions which can reasonably be foreseen as indicated in the Machine Directive 2006/42/CE article 4 paragraph 1, the customer takes the whole responsibility for the usage of the product, especially if not used in an appropriate way, and the warranty, the conformity to the Machine Directive 2006/42/CE and the relative CE declaration are no longer valid. The proper installation, maintenance and use for its intended purpose and the conditions which can reasonably be foreseen are subject to the respect of the technical limits (temperature, working point, compatibility of the pump material with the pumped fluid, NPSH etc...) which are indicated in GemmeCotti's technical data files and use and maintenance manuals.

If the above mentioned limits are not respected, the customer is the only responsible for the introduction of the pump in the market, for the declaration of conformity to the Machine Directive and the CE mark. In any case the user is considered the one who knows better the chemical compatibility and the reactions between the liquid to be pumped and the material of construction of the pump and consequently the information given in this regard by GemmeCotti is merely indicative.

If the returned piece is no longer covered by guarantee, or if after inspection GemmeCotti finds the piece to be not defective, inspection charges will be charged to the customer and the repaired or substituted piece will be returned to the customer at the customer's own expense.

Pumps which have been repaired or substituted under guarantee will be supplied on the same delivery conditions as the order and the warranty will not be extended.

Warranty does not cover components subject to natural wear due to time, such as mechanical seals, bearings, bushings and lip seals.

The customer is solely responsible for the good performance of pumps and for their careful maintenance. Therefore no claims will be allowed when goods have been improperly handled (not stored in a suitable closed dry place, which is necessary because of the fragility of materials), contaminated, handled with negligence, improperly installed, tampered with or not well regulated, incorrectly used in wrong applications. In particular, GemmeCotti will not take any responsibility in the case of wear due to corrosion.

Ordinary maintenance and repair executed outside GemmeCotti authorized network, will cause invalidation of the warranty and of the CE declaration of conformity.

The warranty does not cover damages due to extraordinary or natural events, such as lightning, ice, fire and others.

All the warranty obligations are considered fully satisfied after the repair or substitution of the defective parts.

The Warranty service will be suspended in the case of default or delayed payment and the period lost cannot be recovered.

This warranty is an integral part of the offer and of the order confirmation.

In the case of litigation the court which has jurisdiction is the Busto Arsizio (Italy) Tribunal and the law that will be applied is the Italian Law.

8.2 Returned parts and repair

All our distributors offer a complete repair service. Contact your local distributor or GemmeCotti s.r.l. directly.

Before sending the pump back to our repair services or to GemmeCotti, the pumps have to be decontaminated from the used dangerous liquids. Before sending the pump the customer has to fill in the Decontamination Declaration and send it by e-mail or fax as per the facsimile document in the next paragraph 8.3.

8.3 Decontamination Declaration ⁴ (facsimile)

GemmeCotti Srl
Via Po 23/25/27, - 20031 Cesate (MI)
Telephone 02. 96460406

SUBJECT: Decontamination Declaration of pumps to be repaired

Reference to our Transport document No: _____ dated: _____

Type of pump: _____ Serial Number: _____

Fluid pumped: _____

Type of problem/damage: _____

In accordance with current requirements regarding the health and safety of workmen, we hereby declare that:

1. The pump has been carefully cleaned and decontaminated to remove all traces of the pumped fluid
2. Also the residual fluid used to decontaminate the pump has been removed
3. It is possible to proceed with the repair of the pump without risks for the workmen or the environment

Attention: if the pump is not correctly cleaned or we do not receive this document duly filled in, it will be sent back at the customer's expense

Date _____

STAMP AND SIGNATURE

⁴ TO BE COMPLETED ON THE CUSTOMER'S LETTERHEAD

8.4 CE CERTIFICATE FOR HPP-HPF SERIES PUMPS

Declaration of conformity ⁵ (facsimile)

to the Machinery Directive 2006/42/EC

EC DECLARATION OF CONFORMITY

We declare under our sole responsibility that the pump:

Brand: GEMMECOTTI

Type:

Model:

Serial Number:

Year:

as per described in attached documentation, is in accordance with the Machine Directive CE 2006/42 (ex 89/392/CEE - 91/368/CEE - 93/44/CEE – 93/68/CEE-98/37 CEE) only if it's used for the liquids communicated by the customer..... and for the pump characteristics required with regard to the order No.....dated.....

If the pumped liquid and the needed performances have not been communicated to GemmeCotti and/or the pump is not properly installed, maintained and used for its intended purpose or under conditions which can reasonably be foreseen, the customer takes the whole responsibility of the products as indicated in our warranty Mod. 1.11.4E.

The conformity to the previously mentioned requirements is expressed by the marking:



ENRICO GEMME
(General Manager)
CESATE , there

Signature

⁵ In cases where the customer does not communicate the type of liquid used in the pump and the expected operating conditions, the EC Declaration of Conformity will not be issued and the customer will assume the responsibility and burden of providing for the Certification of the pump in its application.

8.5 ATEX/CE Certificate for Zone 2 (facsimile)



EU Declaration of conformity

The magnetic drive pump type:

SN

Together with all the pumps series:

EM(-C-T-P) PP/PVDF
bearing the mark:

CE  II 3G Ex h IIB T6 Gc

models:

EM-C 6 PP/PVDF, EM-C 10 PP/PVDF, EM-C 15 PP/PVDF, EM-C 31 PP/PVDF, EM-C 40 PP/PVDF, EM-C 50 PP/PVDF, EM-T 2000 PP/PVDF, EM-T 3000 PP/PVDF, EM-T 5000 PP/PVDF, EM-T 7000 PP/PVDF, EM-T 9000 PP/PVDF, EM-T 12000 PP/PVDF, EM-T SP 5000 PP/PVDF, EM-T SP 7000 PP/PVDF, EM-T SP 9000 PP/PVDF, EM-P 100 PP/PVDF, EM-P 200 PP/PVDF, EM-P 300 PP/PVDF, EM-P 400 PP/PVDF, EM-P 600 PP/PVDF, EM-P 800 PP/PVDF.

have been manufactured by GemmeCotti s.r.l. in accordance with the following EC directives:

2014/34/EU (ex 94/9 EC), 2006/42 EC

and the following standards:

EN 12100, EN 13857, EN 809, EN 1127-1, EN 80079-36, EN 80079-37

The manufacturing process is internally controlled by a Quality Management System according to ISO 9001:2015 standards and the internal control of production file n. 101 ext. 0107, is deposited at CESI, notified body N 0722.

This declaration of conformity is issued under the sole responsibility of the manufacturer.



ATTENTION: the above magnetic drive pumps, considered as components, comply by design with the directive providing that installation is correctly performed by the manufacturer of the machinery. The pump must not be put in use until the machinery in which it has been incorporated is declared in conformity with the Machinery Directive. This declaration does not imply any warranty of warranties. The safety instruction of the incorporating product documentation shall be observed.

Since there is an inherent variety of products and chemical compositions that can be suitable to be employed by the considered devices, the end user is the only responsible to verify the reactions and suitability with materials used to build the pump. Therefore, if necessary tests and checks must be performed with great care to avoid any risk, and any concrete event that cannot be foreseen by the manufacturer and of which the manufacturer cannot be held responsible. Every issue lies within competence of Varese Court.

Enrico Gemme
General Manager

Cesate, Date: _____



Via Po 23-25-27 - 20031 - Cesate (MI) ITALY - EU

www.gemmecotti.com

Tel. +39 02 96460406 - info@gemmecotti.com

Mod 4.2 (13/17)