



HTT PP-PVDF PUMPS **EM-T PP/PVDF PUMPS (ATEX ZONE 2 VERSION)**

Thermoplastic mag-drive turbine pumps



INSTALLATION, OPERATION AND MAINTENANCE MANUAL

Translation of the original instructions

(SAFETY INSTRUCTIONS)

Index

1. INTRODUCTION.....	4
1.1 General	4
1.2 Purpose of the Manual.....	4
1.3 Safety Alert Symbols	4
1.4 Qualification and training of operators	4
1.5 Explosion Hazard Environment.....	5
2. INSTALLATION	5
Premise	5
2.1 General Safety Warnings	5
2.1.1 Premise on the hazard	5
2.1.2 Hazard information	5
2.2 Inspection at Reception.....	6
2.3 Storage.....	7
2.4 Installation and Fixing	7
2.5 Hydraulic system	7
2.6 Suction and delivery hose connections	7
2.7 Control tools.....	9
2.7.1 Control of pump in explosive atmosphere zones ATEX ZONE 2.....	9
2.8 Motor Connection.....	10
3. SERVICE.....	11
3.1 Use and Safety	11
3.2 Dry Running.....	12
3.3 Temperature.....	12
3.4 Before Starting.....	12
3.5 Start-up	12
3.6 Optimal conditions of use	13
3.7 Shutdown.....	13
3.8 Long Pump Inactivity.....	13
3.9 Noise Level.....	13
4 MAIN PARTS	14
4.1 Family HTT PP-PVDF	14
5 MAINTENANCE	15
5.1 General provisions.....	15

5.2 Inspections	15
5.3 Procedure Before Disassembly.....	16
5.4 Disassembly	17
5.4.1 Detaching the pump from the motor.....	17
5.4.2 Pump Disassembly	18
5.5 Mounting.....	19
5.6 Replacing the Engine.....	19
5.7 Tightening Torques.....	19
6. TROUBLESHOOTING	20
7. SPARE PARTS AND ACCESSORIES.....	21
7.1 How to order spare parts and accessories	21
7.2 Accessories for the HTT Series.....	21
7.2.1 Flanges	21
7.2.2 Footings.....	21
7.2.3 A1-13Y – Device Contro La Marcia A Secco.....	21
8. DATA	22
8.1 Characteristic Curves.....	22
8.2 Dimensions	23
8.3 Technical Data and Limitations	24
9. WARRANTY AND REPAIR.....	24
9.1 Warranty.....	24
9.2 Parts Returns and Repairs.....	26
9.3 Declaration of remediation (facsimile)	27
9.4 CE CERTIFICATE FOR HTT SERIES PUMPS.....	28
9.5 ATEX/CE Certificate for Zone 2 (facsimile).....	28

1. INTRODUCTION

1.1 General

This manual refers to the HTT family of magnetic drive regenerative turbine pumps. The pumps of this family are made of thermoplastic material (PP or PVDF) and in different sizes. The available sizes and capacities are described in paragraph 8.DATA.

1.2 Purpose of the Manual

The primary purpose of the manual is to ensure that the installation, use and maintenance of the pumps are carried out correctly and safely by the various operators in charge of these operations. The document also provides useful information to the customer for diagnosing problems, finding spare parts and accessing the repair service offered by GemmeCotti s.r.l.

WARNING: check the [website www.gemmecotti.com](http://www.gemmecotti.com) if any revisions have been released since this manual.

1.3 Safety Alert Symbols



This symbol indicates possible hazards induced by the presence of electric fields, contacts or wires with electric voltage.



The exclamation mark signs in this manual indicate a situation of particular importance that requires operator attention. In particular, they are useful indications for the correct operation and prevention of possible damage to the devices.



This symbol indicates the presence of strong magnetic fields that can damage or impair the operation of other devices if placed nearby.



This symbol indicates a hazard or situation that requires the operator's full attention. It is essential to follow the instructions provided in the margin of this symbol and proceed with the utmost caution. It is necessary to inform all operators and/or users that the rules indicated prevent accidents.

1.4 Qualification and training of operators



Personnel in charge of the installation, operation and maintenance of the pumps must be qualified to perform the operations indicated in this manual. GemmeCotti cannot be held responsible for the insufficient level of preparation and training of the customer's personnel or of companies to which the assembly and installation of the pumps is contracted and for the fact that they have not been informed of the contents of this manual. It is essential that operators in charge of the installation, operation and maintenance of the pump always provide this manual. Keep this manual in a safe place for future reference.

1.5 Explosion Hazard Environment

The HTT pumps described in this manual may not be used in potentially explosive environments. For this type of use, special pumps built by GemmeCotti with special materials and devices are required. The customer who intends to use special pumps in this type of environment must consult the GemmeCotti technical department for a correct choice of the item.

This manual applies to turbine pumps only.

The pump models, built by GemmeCotti, for this type of application can be distinguished by the acronym EM-T.

The model, EM-T pumps made of PP or PVDF can only be installed in ATEX zone 2 II3G areas. Refer to paragraph 2.7.1. for more information.



IT SHOULD BE NOTED THAT THE CLASSIFICATION OF THE AREA (REF. ATEX DIRECTIVE 2014/34/EU ex 94/9/EC) FOR ENVIRONMENTS WITH DANGER OF EXPLOSION MUST BE MADE BY THE CUSTOMER AND COMMUNICATED TO GEMMECOTTI FOR THE CHOICE OF THE TYPE OF PUMP SUITABLE TO WORK IN THESE ZONES

It is also the customer's responsibility to install the pump correctly in accordance with the requirements of the Directive

2. INSTALLATION

Premise

All references made to pumps are to be considered applicable to systems using these pumps unless otherwise specified.

2.1 General Safety Warnings ¹

2.1.1 Premise on the hazard



WARNING: Failure to follow the directions in this manual or improper use of the equipment by unqualified and unauthorized personnel could result in serious personal injury or death and damage to products and property!

The technical assistance service is at your complete disposal; for any doubts or problems you can contact us by phone at +39 02 964 60 406 or write an email to info@gemmecotti.com. It is strongly recommended that you keep GemmeCotti's written answer.

2.1.2 Hazard information



For the safety of the operators involved in installation operations, it is necessary to use protective clothing and personal protective equipment approved according to current legal provisions (i.e. safety glasses, gloves and insulating and protective footwear against crushing).



The pump contains magnets of particular power. It is forbidden for personnel with cardiac pacemakers, defibrillators, electronic medical devices, metal heart valves, metal prostheses or sickle cell anemia to handle or be in the vicinity of the magnets contained inside the pumps. Consult an occupational physician for specific recommendations before working with these pumps.

¹ Failure to follow the warnings provided may void the Pump Certification and Warranty



The strong magnetic fields present in the vicinity of the pumps can damage heart pacemakers, watches, credit cards, disks and magnetic tapes inside computers and computers.



When working near pumps, be aware that tools or metal parts handled can suddenly be attracted to the pump body, possibly causing crushing fingers or hands.



These pumps have been designed and built for use in specific conditions and within defined limits. Use outside of these specifications must be agreed and approved by GemmeCotti's technical service. **It must be borne in mind that if pumps are used outside of their technical specifications, the CE Certification and Warranties are void. Furthermore, if the pump is used outside the technical specifications communicated in the quote phase and confirmed with our order confirmation, the user assumes all responsibility for the CE certification of the product.**



The pump should only be used in the applications specified in the order for which GemmeCotti has selected the model, materials of construction and tested the pump to meet its specifications. For any use other than what is communicated with the order, a written request must always be made to the technical department of GemmeCotti which in turn will respond in writing.



No warranty is provided for repairs or alterations made to the product by users or by third parties not specifically authorized by GemmeCotti.



Always stop the pump before touching it or carrying out any work on it or in the installation circuit.



Make sure that the mains power supply to which the pump will be connected is of adequate power and has the correct protective devices (i.e. earthing, circuit breaker).

Always disconnect the electrical supply before working on the pump for maintenance or replacement of parts.



Always keep a fire extinguisher in the vicinity of the pump installation.

Always take extreme care when performing maintenance tasks on pumps and related circuits when they are used with hazardous liquids.



The use of an electric starter is recommended. A simple switch may not be enough to start and stop the electric motor connected to the main power line. An appropriate starter:

- it helps prevent accidental starting after a failed starting attempt;
- provides a safe switch, protected against water;
- protects the electric motor against short-circuit overloads (a fuse only protects the wires);
- It resists overload starts on the motor, preventing dangerous electric arcs and premature wear of the electrical contacts.

2.2 Inspection at Reception

Although all precautions have been taken before packing, we recommend that you carefully check the material received. Review all items on the packing list. Make a written report immediately for any damage or deficiencies attributable to the carrier and/or GemmeCotti.

ATTENTION: Check the nameplate data of the pump received and compare them with those relating to your purchase order. Also compare the dimensional correspondence

(through the overall drawing provided to each customer)

If the pump came with the motor, remove the protective shield of the motor fan and try rotating the motor shaft by hand. If you feel a strong resistance to rotation or if you hear abnormal noises, call your trusted dealer or directly the GemmeCotti assistance service.

2.3 Storage



If the pump is stored in stock, make sure that this is done in a non-humid and sheltered location; always use the original packaging or equivalent protection. If the pump is left in storage for very long periods and/or in particularly humid environments, the use of hygroscopic substances (silica gel) is recommended to prevent damage.



Do not remove the flange protections until the time of installation and if not already closed, plug the holes in the intake/delivery and air connection manifolds to prevent the intrusion of foreign bodies.



It is warned that prolonged storage time of the pumps may result in:

- degradation of the engine insulation due to moisture absorption
- Seal degradation

2.4 Installation and Fixing



GemmeCotti s.r.l. cannot be held responsible for damage to persons or objects caused by improper installation or carried out by unqualified personnel.

Install the pump in a location that allows for easy service.



The motor/pump unit must be fixed on a rigid structure that allows the entire structure to be supported. The suction and delivery pipes must not weigh on the nozzles/flanges of the pump. The load of these pipes must be unloaded on special supports positioned just before the delivery and suction of the pump. Make sure that the pump is fixed on a surface, if necessary use the bases supplied by GemmeCotti or shims under the motor support bases. Where deemed necessary, use "bumpers" to reduce vibrations towards the fixing surface.

2.5 Hydraulic system

The pump is generally part of a hydraulic system that can include a number of components such as valves, equipment, filters, expansion joints, tools, etc. The way the implant is performed and the placement of its components has a great influence on the operation and life of the pump.



It is advisable to wash the new systems internally before installing the pump to remove any processing residues to prevent them from entering it and damaging it.

2.6 Suction and delivery hose connections ²

Position the pump as close as possible to the source of the liquid to be handled and below the level of the liquid itself (under the head).



When suction, always use hoses as short as possible, limiting bends to a minimum and ensuring the largest possible bend radii. Avoid air pockets that may arise in long pipework. Do not create siphons before the pump is suctioned.



The pipes must be supported and kept in line independently of the pump, up to its

² Failure to follow the warnings provided may void the warranty terms on the pumps supplied.

connections, so as not to burden it.

The diameters of the suction and discharge pipes must be at least equal to the diameter of the pump manifolds. Narrowing on the suction pipe are responsible for and cause pump cavitation, leading to a loss of performance and rapid wear. It is recommended to always use reinforced hoses that will not collapse in a vacuum situation.



The suction line must be cleaned and/or equipped with a filter to protect the impeller from damage due to slag, or other foreign particles, especially when the system is first started.

Never pair metal piping onto plastic pumps.



Tightening the pipes on plastic pumps must be carried out without the use of tools. Make sure the connections are carefully tightened otherwise the suction capacity will be reduced.

A pressure gauge should be installed in both suction and discharge piping. Installing pressure gauges will allow the operator to easily check the correct operation of the pump in relation to the required operating point. In the event of cavitation or other malfunctions, noticeable pressure fluctuations will be observed.



WARNING: The pump is reversible. If you want to reverse the suction and discharge, carefully follow the instructions on the pump label. However, it is advisable to install it as shown in B in the image, i.e. clockwise direction of rotation looking at the pump body

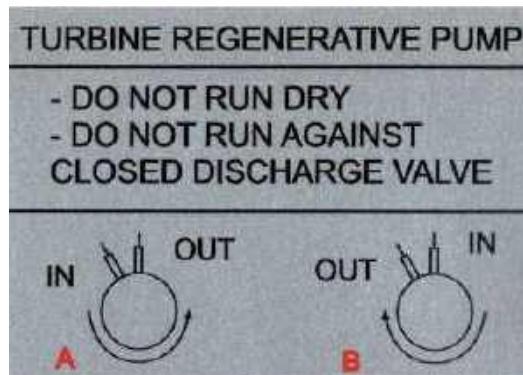

2.7 Control tools



Depending on the importance of the pumping circuit, it may be useful to maintain strict control over the performance and condition of the process. The use of pressure measuring instruments on the suction and discharge circuits may be recommended.

The measurement of the electrical power absorbed by the motor can also be measured by means of the use of a wattmeter.



If the temperature of the pumped liquid can be a critical element, insert a thermometer into the circuit, preferably on the suction line.

These control tools can warn you of any abnormal pump operating situations such as: accidentally closed valves, missing liquid, overloads, etc.

2.7.1 Control of pump in explosive atmosphere zones ATEX ZONE 2

In addition to complying with the general warnings specified in this manual, special pumps to be used in potentially explosive environments must be installed with the control devices specified in this paragraph in order to maintain close monitoring of process performance and condition. Control devices mounted in the vicinity of the pump shall be certified for the same hazardous area identified for the installation of the pump unless they are protected by watertight cabinets which are themselves certified.

To avoid overloads on the pumps due to impurities or solid particles in the pumped liquid, the use of a filter in the suction line is strongly recommended. This filter has to be regularly checked to avoid obstruction.

The installation of pumps of type EM-(C-T-P) for use in potentially explosive environments must comply with the rules of the ATEX Directive 2014/34/EU.

In particular, the manufacturer's requirements applicable to **Category 3 of Group II** appliances (explosive atmosphere due to the presence of gases, vapours or mists) are as follows:

- Appliances must be designed and constructed in such a way as to avoid ignition sources that can be expected during normal operation.
- Under the intended operating conditions, surface temperatures shall not exceed the maximum design temperatures stated (paragraph 3.1). Any exceedance is tolerable, in exceptional cases, if the manufacturer takes additional special protective measures.

The temperature classes are defined as per the table:

Temperature class according to ISO80079-36	Temperature limit of the liquid
T6 (85°C)	60°C
T5 (100°C)	75°C
T4 (135°C)	110°C
T3 (200°C)	175°C

- The ambient temperature must be between -20°C and 40°C as per ISO 80079-36
- The temperature of the fluid must be monitored in suction.
- Warning: the table with the temperature ranges is valid only in optimal conditions of use of the pumps (rpm, flow rate, head and NPSHa) of correct lubrication and maintenance.
- In any case, the fluid temperature must not exceed the pump's maximum or minimum design temperature (see section 3.1)



It is not recommended to mount the suction filter to avoid obstruction to the suction of the pump which can cause cavitation and/or dry running. A suction filter can only be useful during the start-up phase, for cleaning the same and in any case it must be monitored to avoid clogging that would lead to the correct operation of the pump.



If unacceptable working conditions are detected, the pump must be stopped automatically and overhauled.



NPSHa may decrease as a result of the installation of a valve or bends, filters, elbows on the suction line, in this case it is necessary to install a flow meter to check for any variations.



The pump is supplied with a metal front ring and therefore with an accurate ground connection of the same there can be no unwanted electrostatic charges as a source of ignition for explosions.



The pump installed in ATEX zone 2 must be coupled to a suitable explosion-proof motor.

2.8 Motor Connection

Check that the voltage and frequency on the motor label match those of the mains supply you are to use.



Never connect the electric motor directly to the main line but protect the dedicated line with a suitable main switch with the appropriate protections for safety and overloads.



Electrical connections should always be made by a qualified experienced electrician. The motors supplied must be powered with three-phase voltages or, if required by the customer, single-phase. The type of connection in three-phase motors can be star (Y) or delta (Δ) according to the 400 or 230 VAC power supply line (see figure 1).

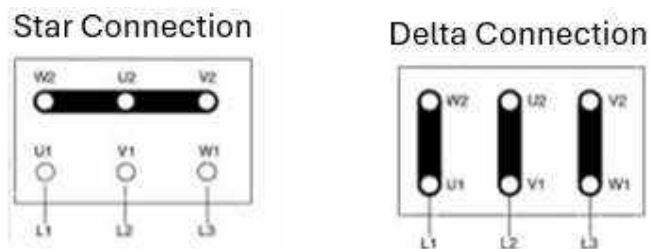

Figure 1



Make sure that the direction of rotation of the motor is as desired. See the WARNING in point 2.6 ; to reverse the direction of rotation, it is sufficient to invert two of the three input lines (e.g. L1 with L2) in three-phase motors.



To test the direction of rotation follow these instructions:

- wear approved personal protective equipment (i.e. goggles, gloves)
- ensure that the conditions of use comply with the pump specifications (see section 8)
- Install the pump in the hydraulic system
- Fully open the intake and exhaust valve
- Allow the liquid to flow inside the pump. It is recommended to carry out this test with an inert liquid such as water.
- never allow the pump to run dry (N.B. the design of the pump with magnetic drive does not allow dry operation as this would irreparably damage the internal components of the pump)
- Power the motor only for one or two seconds to observe the direction of rotation that complies with the plate on the pump given in paragraph 2.6 of this manual.

3. SERVICE

3.1 Use and Safety

ATTENTION:

Dangerous or risky practices can cause serious injury or death to persons or serious property damage, it is therefore essential to ensure compliance with all safety and correct use warnings provided in this manual.



Always check that the fluid being pumped is compatible with the materials of construction of the pump. Check that the pump you receive corresponds to what you ordered by means of the dimensional check (dimensional drawing) and compare the data on the pump plate with the data provided when ordering. For any clarification, contact the technical office of GemmeCotti.



When used for pumping aggressive, toxic or health-threatening liquids, adequate protection must generally be installed on the pump for containment, collection and signalling of the hazardous product in the event of spillage: e.g. DANGER OF POLLUTION, CONTAMINATION, INJURY AND/OR DEATH.



Avoid pumping liquids containing suspended solids. Magnetic drive pumps are designed to pump clean liquids. It is not recommended to mount the suction filter to avoid obstruction to the suction of the pump which can cause cavitation and/or dry running. A suction filter can only be useful in the start-up phase, for cleaning the same and in any case it must be monitored to avoid clogging that would lead to the correct operation of the pump. In particular, avoid pumping liquids containing iron oxides or other ferromagnetic particles, even small ones. If in doubt, call the GemmeCotti technical service (tel. +390296460406).



Never restrict your intake. Narrowing of the suction is responsible for pump cavitation, which leads to loss of efficiency and rapid wear. Narrowing of the discharge is not advisable, reductions in the flow rate, if required, can be obtained by means of a valve installed on the delivery pipe.

Never loosen the pump connections while it is under pressure.

Do not start and/or run the pump if there are traces of leaks in the circuit.



The operating temperatures must be such as to comply with the characteristics of the construction materials used in the pump:

- 0- 60 °C polypropylene (PP) design
- 0- 80 °C PVDF design



NEVER RUN THE PUMP DRY (N.B. the design of the pump with magnetic drive does not allow dry operation as it will irreparably damage the internal components of the pump)



- An accidental failure can generate splashes up to a considerable distance.
- In case of vibrations or abnormal noises, stop the pump immediately.
- Do not pump flammable liquids.
- Do not touch the pump while it is running.
- Before touching the motor or bracket, switch off the electric power.

3.2 Dry Running



Fill the pump with water (if compatible with the process liquid) or with the liquid to be pumped before starting the pump. This will protect the pump sleeves and shaft against dry running. **NEVER RUN THE PUMP DRY** as serious damage can be caused by lack of lubrication to the internal components of the pump.

3.3 Temperature



Increasing the temperature of the fluid being handled may damage the pump and/or the system pipes and may cause a situation of serious danger to people in the vicinity. Avoid sudden changes in temperature and do not exceed the temperatures specified in the order. See the temperature values of the pump construction materials in section 3.1.

3.4 Before Starting

Be sure that the pump is installed in accordance with the instructions provided in section 2 above.



When the pumping station is new, the system should be filled with water (or other inert liquid) to check for leaks. **IF THE PUMP IS MOUNTED ABOVE THE HEAD, IT MUST BE PRIMED, I.E. FILLED WITH LIQUID, AND THE SUCTION PIPE MUST BE KEPT FULL OF LIQUID BEFORE START-UP**



WARNING: Some liquids react with water. **CHECK IF THE LIQUID TO BE PUMPED REACTS WITH WATER. IN THIS CASE, THE SYSTEM MUST BE COMPLETELY EMPTIED AND DRIED.**

3.5 Start-up

Start the electric motor and open the delivery duct gradually until the desired flow is achieved.

It is advisable not to run the pump with the delivery circuit closed for more than two or three minutes. A longer period may cause serious damage to the pump.

If the pressure indicated by the output control tools does not increase, turn off the pump immediately and release the pressure gradually.

Repeat the pump installation operations as per paragraph 2.

If during the start-up phase there are changes in the flow rate, density, temperature or viscosity of the liquid, stop the pump and contact the technical assistance service of GemmeCotti s.r.l..

3.6 Optimal conditions of use

Continuous operation at maximum performance (maximum pressure/flow rate) can lead to premature pump wear. As a good practice, we recommend using the pump at half its maximum flow rate (see section on technical data).

In any case, never let the pump work out of curves.



The flow rate and head of the pump refer to pumping water at room temperature. If liquids are to be pumped at high temperatures or high viscosities and densities, the performance must be correspondingly reduced. The HTT series pumps work well with liquids with viscosities up to 100 CPS³ and specific weights up to 1.9 kg/dm³. **IN ANY CASE, BOTH VISCOSITY AND SPECIFIC GRAVITY MUST BE COMMUNICATED DURING THE REQUEST FOR QUOTATION PHASE, THE ELECTRIC MOTOR IS SELECTED FOR THE VISCOSITY AND SPECIFIC GRAVITY COMMUNICATED, IF THEY ARE HIGHER, THE POWER OF THE MOTOR MAY BE INSUFFICIENT.**

3.7 Shutdown

Normally the pump should only be stopped after the outlet valve has closed. If the suction valve is closed earlier, cavitation of the pump can occur.

In the event that the suction is flooded, close the valve after stopping the pump.



In some cases the pump could be used to empty tanks or cisterns, in these cases it may happen that the liquid stops flowing into the pump while it is still working. In these cases, a pump that operates without liquids (and therefore dry) can be seriously damaged if it is not immediately stopped. For this type of use, it is recommended to use automatic stop devices or the constant presence of an operator who can promptly stop the pump.

3.8 Long Pump Inactivity



If the pump remains stationary for a long period, before proceeding with the stop, it is advisable to circulate water in the circuit for several minutes, thus avoiding the risk of internal encrustations or precipitation of solid parts. Then drain the liquid into the pump. Freezing of the liquid inside the pump may cause damage. In any case, check whether the pumped liquid reacts with water. In this case, contact GemmeCotti to verify an alternative solution.

In cases where the pump is temporarily removed from the system and stored, the instructions given in section 2.3 "Storage" must be followed.

3.9 Noise Level

In some circumstances, for example when the pump works with high pressure and low flow rate, the noise increases and can be annoying to personnel working nearby. In this case, it is possible to intervene with:



- earplugs;
- protective ear defenders approved for nearby personnel;
- soundproofing devices for the pump. In these cases, make sure that the ventilation of the motor is guaranteed.

³ The values quoted are purely indicative and may vary within the HTT series pump family

4 MAIN PARTS

4.1 Family HTT PP-PVDF

The attached images show a section and an exploded view of the parts constituting a pump of the HTT family with the exclusion of the motor.

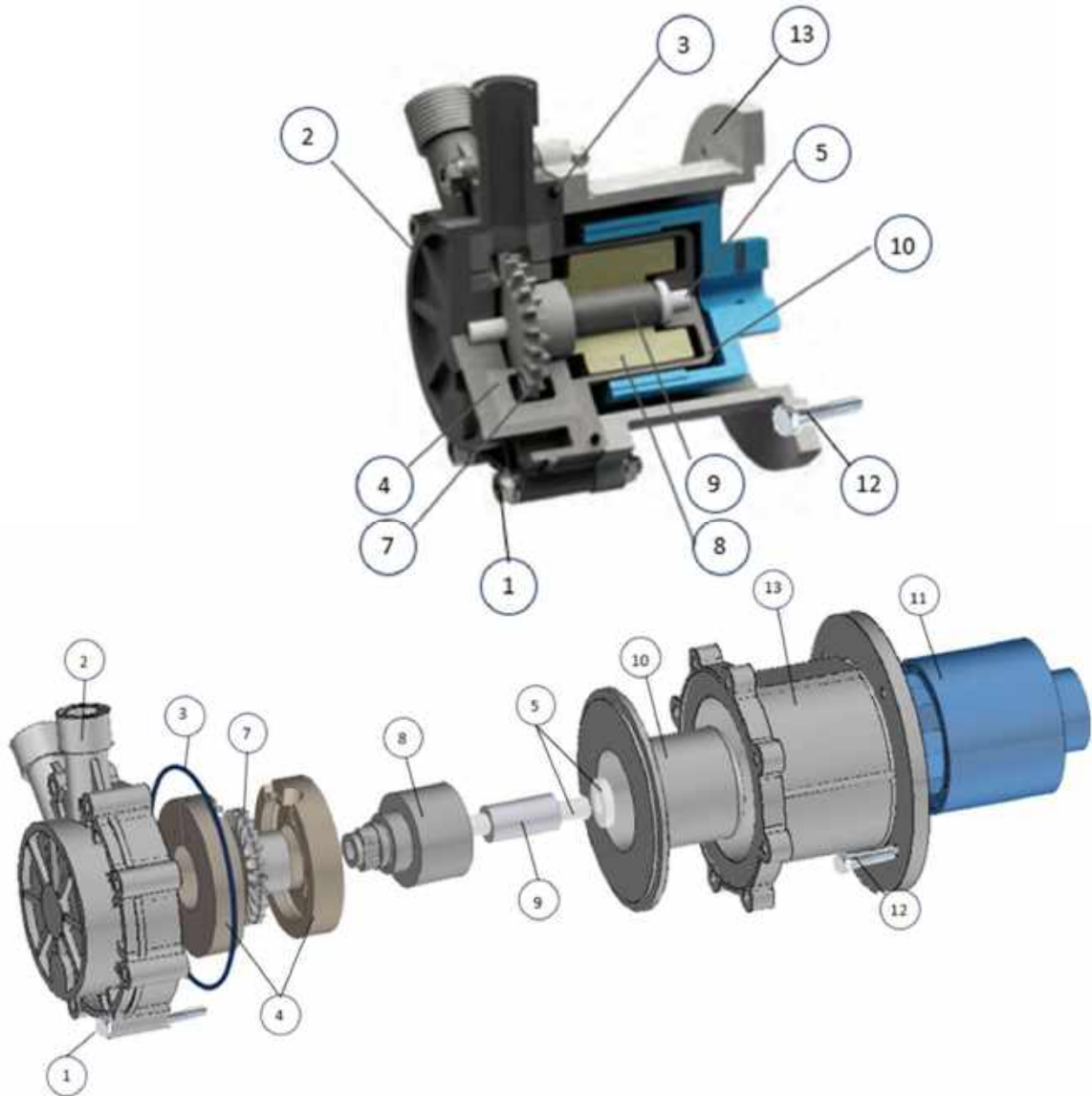

POS	1	2	3	4	5	7	8	9	10	11	12	13
PART DESCRIPT	SET SCREWS	PUMP HEAD	O-RING	FRONT AND REAR DISC	SHAFT + RING	IMPELLER	INT MAGNET	BEARING	REAR CASING	EXT MAGNET	SCREWS	BRACKET
MATERIALS	AISI 304	PP PVDF	EPDM VITON	PP PVDF	AL2O3	PVDF	PP PVDF NdFeB	PTFEC	PP PVDF	C40 NdFeB	AISI304	PP

5 MAINTENANCE

5.1 General provisions



During the warranty period, no extraordinary maintenance operation of the pump must be carried out except by personnel of GemmeCotti or authorized by GemmeCotti. All the operations described in the following paragraphs must be carried out only by suitably qualified personnel and following all the warnings included in this manual step by step.

In the case of routine maintenance of the pump, the customer is responsible for the correct disassembly and assembly. The warranty is void in the event of tampering with it, use of non-original parts or in the event of practices that do not comply with what is indicated in this manual.

During routine maintenance of the pump, the customer is responsible for checking the seals (by hydrostatic test, taking care to comply with the pump PN), impeller/magnet alignment, shaft positioning, bushing assembly and checking that the pump is functioning properly. To tighten the screws, refer to the table in paragraph 5.7 and be careful not to pinch the o-ring.

Clean the outer surface of the pumps using only antistatic devices.



Any operation carried out on the machine must be carried out only after physically disconnecting the electrical supply.



The handling of pumps with weights greater than 16 kg must not be carried out manually, but only using hoists or other suitable means. When moving the machine or parts of the machine, avoid knocks or falls that could damage the devices.



Before disassembling pump parts, make sure that hazardous internal liquids have been properly removed/washed. **THE PUMP MUST BE QUENCHED.**



Be aware that some internal liquids may have dangerous reactions when in contact with water.



When discharging hazardous liquids, make sure that there are no situations that pose a danger to people or the environment.

5.2 Inspections

In general, magnetic drive pumps do not require frequent maintenance or disassembly. However, periodic inspections are recommended to check the state of wear of the impeller, shaft, O-rings and bushings and whether the general condition of the internal parts of the pump is good.

The inspection interval is highly dependent on the operating conditions of the pump, the characteristics of the fluid, temperature, materials used and of course the operating time.

After the first start-up, it is advisable to check the bushings after 3 months. If the check is successful, it is advisable to carry out a further check after another 6 months. Subsequent inspection is recommended after one year of operation (approximately 2000 hours). In any case, it is a good idea to replace the PTFEC bushings every 2000 hours of pump operation.

Other components should only be changed when they show obvious signs of wear.

If a problem is found or the pump needs a complete inspection, see the "Troubleshooting" and "Pump disassembly" chapters.

5.3 Procedure Before Disassembly

**ATTENTION:**

If the pump has pumped hot liquids, make sure it has been cooled down before disassembling. The pump may have pumped toxic and/or dangerous liquids, so skin and eye protection should be worn.

**ATTENTION:**

Be sure that you have thoroughly cleared the pump. Flush and neutralize hazardous fluids inside the pump completely. The liquid must be recovered and disposed of according to existing environmental laws. After disconnecting the suction and delivery hoses, close the ends.

**ATTENTION:**

GemmeCotti pumps contain extremely strong magnets. The use of magnetic non-iron tools and worktops is highly recommended.

Beware of the strong magnetic attraction when disassembling/reassembling the motor-external magnet assembly of the pump.



The area where maintenance is carried out must be clean and free of ferrous particles that can be attracted by magnets.

**ATTENTION:**

Wearers of PACE MAKER or equivalent devices cannot operate on or near the pump due to the presence of strong magnetic fields.

**ATTENTION:**

It is recommended not to work in the vicinity of magnets when wearing ferromagnetic wristwatches, bracelets, rings and jewellery and/or with electronic equipment sensitive to magnetic fields.

5.4 Disassembly

NB: The images used to illustrate the disassembly operations refer to a particular model of the HTT family and therefore the pump supplied with you may slightly differ from what is shown.

5.4.1 Detaching the pump from the motor

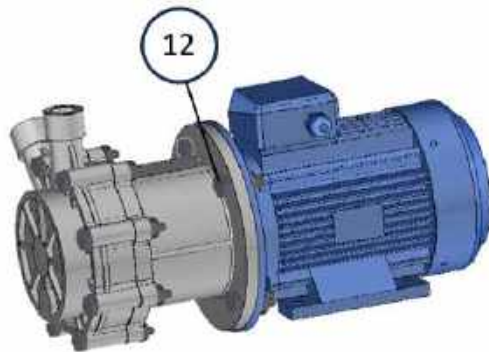

1. Remove the pump tightening screws (12) with the motor flange

2. Separate the pump from the motor

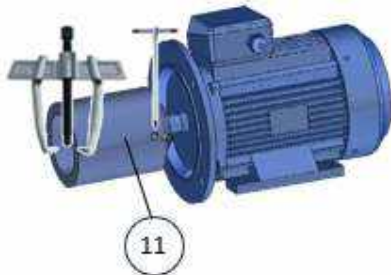
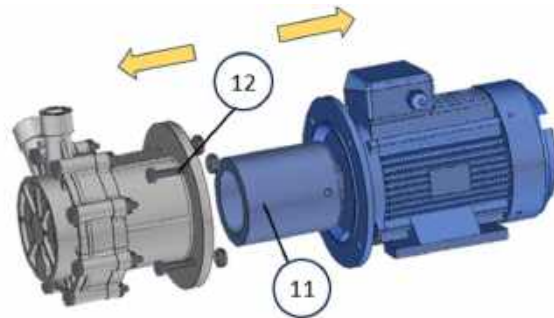

3. If it is necessary to remove the external magnet (11) from the motor shaft, proceed by unscrewing the grub screws with the Allen key and then use an extractor so as not to damage the motor shaft or the external magnet.

5.4.2 Pump Disassembly

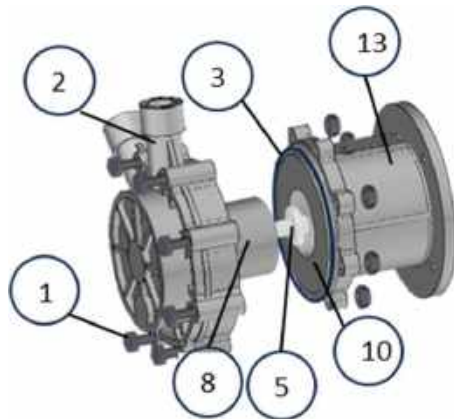

1. Remove the clamping screws (1) to detach the body (2) from the bracket (13) together with the inner magnet assembly (8) with the shaft and ring (5).

Be careful that the shaft and ring are made of ceramic material and therefore very fragile.



Check the shaft (5) and bushing (9) for wear and tear. Be careful because the shaft and ring are made of ceramic material and therefore very fragile.

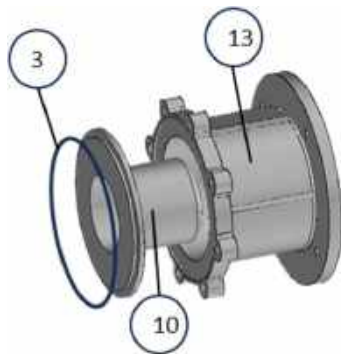
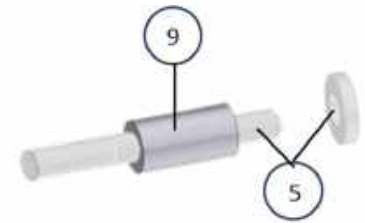

2. Then remove the socket (10) and replace the external O-ring seal (3)

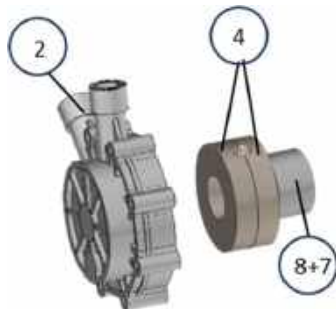

3. Remove the internal magnet assembly (designated GMI) (8) + (7) from the pump housing (2) along with the front and rear head discs (4).

The components that can be periodically replaced are:

- O-ring (detail 3 in the exploded drawing)
- Bushings (detail 9 in the exploded view)
- Static disks (detail 4 in the exploded drawing)

5.5 Mounting

The assembly sequence is mirrored to the disassembly sequence; However, the following warnings must be kept in mind:



ATTENZIONE: Pulire accuratamente ogni componente prima dell'assemblaggio, assicurarsi che tutte le parti siano prive di sporco, particelle metalliche etc



- Place the external magnet on the motor shaft and send it to the stop.
- Then screw the appropriate grub screws, ensuring that one engages the key slot of the motor shaft



- always check that the bushes are correctly seated and if necessary use a manual press for their complete insertion into place;

- Make sure that when the pump is closed, the gasket (O-ring) is perfectly seated and is not pinched.



- When inserting the pump on the motor, pay attention to the magnetic adhesive force that can cause damage to your fingers or hands.

- Use torque wrenches for correct tightening force of the screws according to the table in paragraph 5.7 below.



- After tightening the pump onto the motor flange, momentarily remove the protective fan shield on the rear of the motor and rotate the fan by hand to verify the free rotation of the assembled assembly. If excessive friction or abnormal noise is detected, proceed to disassemble the assembly (operations in paragraph 5.4) and to detect the cause of the anomaly. Under no circumstances should the pump be used without having carried out this check.

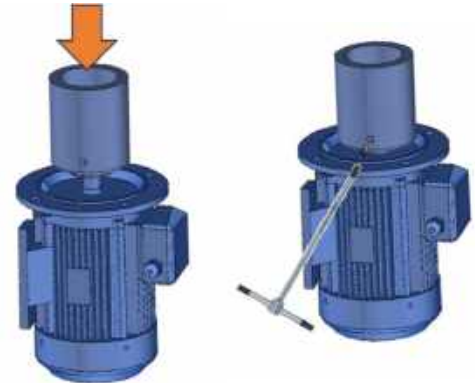

5.6 Replacing the Engine

Proceed as indicated in paragraph 5.4.1 above. Make sure that the characteristics of the motor are the same as the engine being replaced. The manufacturer of the engine may be different from the one previously fitted.

5.7 Tightening Torques

The recommended tightening torques are shown in the table below:

HTT PP/PVDF	HTT 2000		HTT 3000		HTT 5000		HTT 7000		HTT 9000		HTT 12000	
	quic kly	Nm	quic kly	Nm	quic kly	Nm	quic kly	Nm	quick ly	Nm	quic kly	Nm
Motor/pump flange	M5	8/10	M6	8/10	M6	15/20	M8	15/20	M10	15/20	M10	15/20
Pump body / Bracket	M5	6/8	M5	6/8	M6	6/8	M6	6/8	M8	6/8	M8	6/8

6. TROUBLESHOOTING

<i>Motor overload</i>	<i>Insufficient speed of the flow or pressure in the pump</i>	<i>Insufficient pressure from the discharge pipe</i>	<i>Irregular delivery pressure from the pump</i>	<i>Noises and vibrations</i>	<i>Blocked pump</i>	<i>Pump overheating</i>	<i>Anomalous wear</i>	<i>Leak in the pump</i>	Possible cause	Solution
	•								Wrong direction of rotation of the motor	Invert the direction of rotation
	•	•	•	•					Insufficient suction head (NPSHa)	Increase NPSH available: <ul style="list-style-type: none"> • Raise the suction head (positive head) • Lower the pump • Increase the diameter of the suction pipe • Make suction pipe short and straight
		•							Pump clogged	Clean the pump
	•		•	•				•	Cavitation	Increase the NPSH available
	•		•	•				•	The pump sucks air	Check that the joints on suction pipes are tight
		•	•	•					The suction pipe is blocked	Check the valves and filters on the suction line
	•			•					Discharge pressure too high	Reduce the pressure increasing the diameter of pipes and/or reduce the number of valves or bends
	•			•		•			Flow rate too high	Reduce the flow: <ul style="list-style-type: none"> • partially close the discharge valve • reduce the rotation speed
	•			•	•	•	•		Liquid temperature too high	Cool the liquid
								•	Wrong material of the o-ring for the liquid	Mount o-rings of different material (contact us)
	•			•	•	•			The impeller seizes up	<ul style="list-style-type: none"> • Reduce the temperature • Adjust the distance between the impeller, the rear casing and the pump head
				•	•	•	•		Foreign objects in the liquid	Use a filter on the suction side
		•							Shut off valve closed on suction side	Check and open the valve
	•								Discharge pressure too low	Increase the suction pressure: <ul style="list-style-type: none"> • Install an impeller with bigger diameter (contact GemmeCotti)

7. SPARE PARTS AND ACCESSORIES

7.1 How to order spare parts and accessories

A complete series of spare parts and accessories are available from our warehouse and our distributors. To request them, it is necessary to communicate the pump model, size, material, or serial number, year of construction and the number of the spare part required. These references can be found directly on the pump plate and on the cross-section drawings relating to the pump itself. If you do not have the drawings in the section, contact the GemmeCotti sales office (tel. +39 0296460406).

For European Union countries only It is possible to order pumps, spare parts and accessories via e-commerce at the site <https://gemmecotti.com/shop/>

7.2 Accessories for the HTT Series

7.2.1 Flanges



GemmeCotti pumps are usually supplied with threaded connections. On request, UNI EN and ANSI free flanges with threaded flanges can be supplied.

7.2.2 Footings

For a perfectly horizontal installation of the pump. Available in three versions:



- TYPE "A" suitable for: IEC B3/B5 motors from size 56 to 71
- TYPE "B" suitable for: IEC B3/B5 motors from size 80 to 90
NEMA 56TC and 145TC motors.
- TYPE "C" suitable for: IEC B3/B5 motors from size 100 to 112
NEMA 184TC motors.

7.2.3 A1-13Y – Device Contro La Marcia A Secco



useful tool to prevent costly pump breakdowns as it avoids dry running, overload operation out of curves, closed delivery and blocked suction, .

8. DATA

8.1 Characteristic Curves

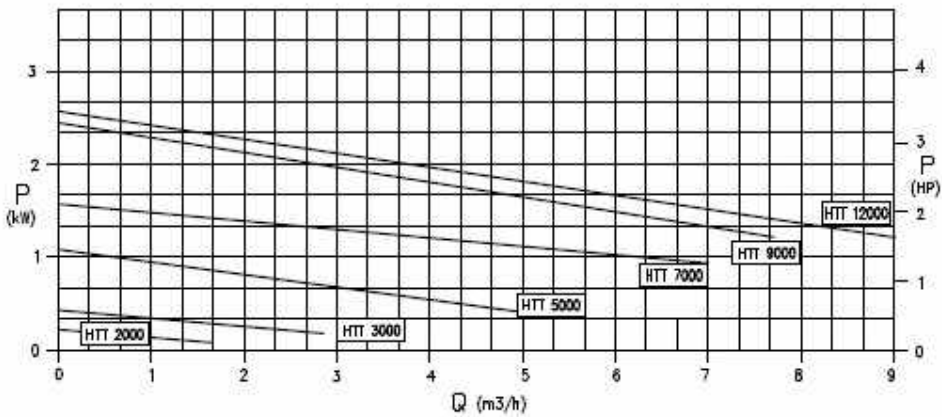
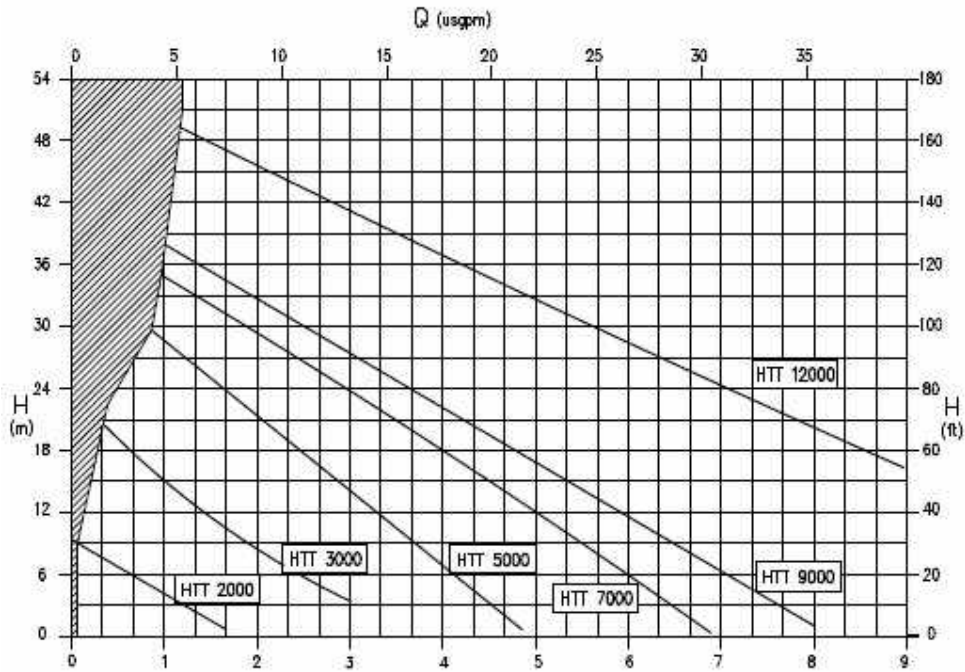

8.2 Dimensions

HTT 2000 - 3000 - 5000 - 7000 - 9000 - 12000 PP/PVDF DIMENSIONI

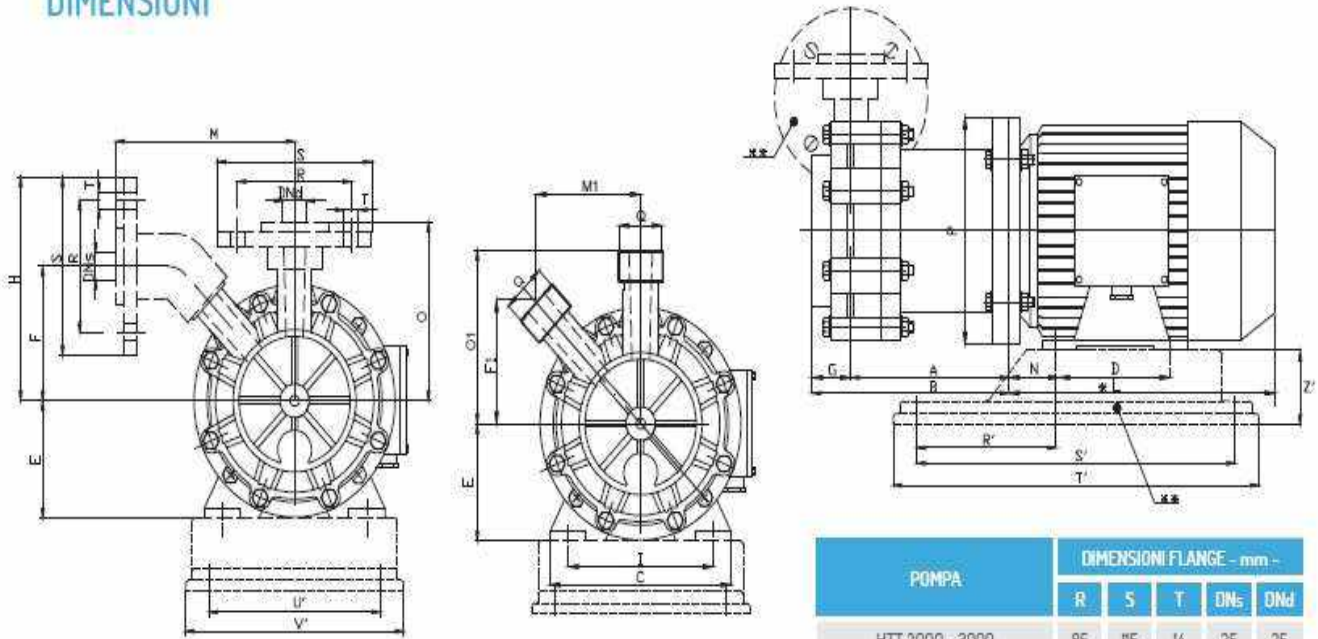

POMPA	DIMENSIONI FLANGE - mm -				
	R	S	T	DN _s	DN _d
HTT 2000 - 3000	85	115	14	25	25
HTT 5000 - 7000 - 9000 - 12000	110	153	18	40	40

POMPA	FLANGIA MOTORE B3 - B5	KW	DIMENSIONI - mm -															DIMENSIONI BASAMENTO - mm -								
			A	B	C	D	E	F	F1	G	H	I	*L	M	M1	N	O	O1	P	Q	R'	S'	T'	U'	V'	Z
HTT 2000	71 A	0.37	118	146	142	90	71	86	78	28	145	112	192	135	78	45	116	110	160	1" MASCHIO	112	244	280	130	160	48
HTT 3000	71 A	0.37	118	146	142	90	71	86	78	28	145	112	192	135	78	45	116	110	160	1" MASCHIO	112	244	280	130	160	48
	71 B	0.55											215													
HTT 5000	80 A	0.75	187	221	160	100	80	110	95	34	187	125	215	189	95.5	50	148	135	200	1 1/2" MASCHIO	128	302	350	157	205	60
	80 B	11											232													
	80 B	11											100													
HTT 7000	90 S	1.5	187	221	170	100	90	110	95	34	187	140	255	189	95.5	56	148	135	200	1 1/2" MASCHIO	132	302	350	157	205	60
	90 L	2.2											280													
HTT 9000	90 L	2.2	187	221	170	125	90	110	95	34	187	140	280	189	95.5	56	148	135	200	1 1/2" MASCHIO	132	302	350	157	205	60
	100	3											315													
HTT 12000	100 L	3	207	241	200	140	100	110	95	34	187	160	315	189	95.5	63	148	135	250	1 1/2" MASCHIO	140	352	400	202	250	60
	G 112 M	4											190													

* Diverso a seconda del fornitore di motori. ** OPTIONAL A RICHIESTA: Basamento e flange.

NOTE: DIREZIONE DI ROTAZIONE ANTIORARIA VISTA LATO VENTOLA MOTORE.

POMPE DISPONIBILI FILETTATE O FLANGIATE.

8.3 Technical Data and Limitations

The specific curves are valid for homogeneous fluids with specific gravity = 1. If liquids with a specific gravity greater than 1 are to be pumped, the absorbed power shown on the characteristic curve must be multiplied by the value of the specific gravity of the liquid to be pumped. For liquids with a specific gravity greater than 2, contact the technical service of GemmeCotti s.r.l. (tel. +390296460406).

The characteristic curves are valid for homogeneous liquids with a viscosity of 1 CPS. If the pumped liquid has viscosity other than 1 CPS, the Q/H values will be altered. The efficiency of the pump will decrease. For liquids with a viscosity of less than 0.5 CPS or greater than 150 CPS, please contact the GemmeCotti technical service.

The required NPSH values are shown on the pumps curve and they are the lowest required values. As a rule, for safety reasons, the NPSH value of the system (NPSH available) must be at least 1 m higher than the required NPSH value (shown on the characteristic curves) to avoid problems due to lack of lubrication or dry running with consequent damage to the bushings. The available NPSH may decrease as a result of the installation of valves on the intake line. It is advisable to use a flow meter to check for any changes.

The efficiency values shown on the curves refer to sample pumps in the prototyping phase. In pumps built in series, these values may be lower. As a rule, these values should be considered reduced as follows:

- Pumps with discharge connection up to 25 mm: -3 points
- Pumps with a delivery connection greater than 25 mm: -2 points

The characteristics of HTT pumps are guaranteed by the manufacturer with tolerances in accordance with the UNI EN ISO 9906:2002 standards – Hydraulic performance tests and acceptance criteria. Compliance with other specifications or regulations requiring tighter tolerances must be specifically requested at the time of the request for quotation; in this case, the most suitable pump will be selected and the required regulations will be considered accordingly.

9. WARRANTY AND REPAIR

9.1 Warranty

All GemmeCotti srl products are covered by a warranty for a period of twelve (12) months from the date of delivery of the goods.

To obtain warranty service, it is necessary that the defect be reported in writing within 8 days of its occurrence, and that the part to be repaired or replaced be sent to GemmeCotti. On-site warranty service is not provided. In case of a warranty claim, it is preferable to send the complete pump, including the motor, to GemmeCotti.

Transportation costs and related risks, as well as any customs duties, are the responsibility of the purchaser and shipments charged to the recipient will not be accepted in any way.

The Manufacturer shall not be held liable for any damage caused during the transportation of parts or of the pump, sent for warranty service.

The warranty system provides that, following a careful examination at our premises,

GemmeCotti shall, at its discretion, repair or replace the part(s) of the pump that show evidence of defects in material or workmanship, or both. No refund or credit shall be given for defective material or for direct or indirect damages, including loss of production, caused by our pumps. In any case, any claim shall not exceed the cost of the pump or material supplied.

If the pumped liquid and the required performance have not been communicated at the time of the quotation, and confirmed by GemmeCotti at the time of the quotation and order confirmation, and/or if the pump is not used in accordance with its intended purpose or under reasonably foreseeable conditions as indicated in the Machinery Directive 2006/42/EC Article 4 paragraph 1, the customer shall assume full responsibility for the use of the product, if used improperly, and consequently the warranty, the declaration of conformity to the Machinery Directive 2006/42/EC and the related CE marking shall lapse. The use in accordance with its intended purpose and the reasonably foreseeable conditions are subject to compliance with the technical limits (temperature, operating point, compatibility of materials with the pumped liquid, NPSH etc.) indicated in the GemmeCotti technical data sheets and in the use and maintenance manuals.

If the above requirements are not met, the customer shall assume responsibility for placing the product on the market and shall be required to draw up a new declaration of conformity and re-mark the pump. The user is in any case considered to be the best expert on the chemical compatibility and reactions between the liquid to be pumped and the pump materials, consequently the information provided in this respect by GemmeCotti is purely indicative.

If the returned product is no longer covered by warranty, or if no defect or fault is found following the examination, the customer will be charged for the inspection costs and the repaired or replaced product will be returned at the recipient's expense. Pumps repaired or replaced under warranty will be supplied under the same delivery terms as the main order and the warranty will not be extended.

The warranty does not apply to components subject to normal wear and tear, such as mechanical seals, bearings, bushings and lip seals.

The purchaser is solely responsible for the correct use of the pump and for its careful maintenance. Consequently, the warranty will not apply to pumps that have been poorly stored (not stored in a closed and dry place, necessary due to the delicacy of the materials purchased), contaminated, handled negligently, installed incorrectly, tampered with or improperly adjusted, improperly used in applications and/or wrong conditions. In particular, GemmeCotti shall not be liable for wear caused by corrosion.

Ordinary repair and/or maintenance operations must be carried out in accordance with the instructions in the use and maintenance manual and performed by persons experienced in the field of pumps. Any modifications or tampering not authorized by GemmeCotti shall void the warranty and the CE declaration. In this case the customer shall assume the product risk and shall draw up a new declaration of conformity.

The warranty also does not cover damage caused by extraordinary and/or natural events, such as lightning, frost, fire, etc.

The warranty obligations shall be deemed fully satisfied by the repair or replacement of the defective parts.

The warranty provided shall be suspended in the event of non-payment or delayed payment

and the uncovered period shall not be recovered.

This warranty clause is an integral part of the quotation and order confirmation.

The Court of Busto Arsizio (VA) shall have exclusive jurisdiction over any disputes.

9.2 Parts Returns and Repairs

All our distributors have a complete repair service. Contact your local distributor or directly with GemmeCotti srl.

Before returning a pump to our repair services or directly to GemmeCotti the pumps must be reclaimed of the hazardous liquids used. Before returning the pump, the customer must send a declaration of remediation by e-mail or fax as per the facsimile in paragraph 9.3 below.

9.3 Declaration of remediation ⁴ (facsimile)

Att.

GemmeCotti S.r.l

Via Po 23/25/27- 20031 Cesate (MI)

Telephone 02. 964. 60. 406

Declaration of Reclamation of Pumps on a subcontracting/repair basis

Ref. DDT repair account n° _____ of _____

Pump Type _____ Serial Number _____

Pumped Fluid _____

Fault type encountered _____

In compliance with current safety regulations regarding the protection and safety of operators, the following is declared:

- 1- The pump has been carefully quenched and tempered with a solution suitable for eliminating all traces of operating fluid.
- 2- Residues of washing fluid have been eliminated.
- 3- It is possible to overhaul the pump without any danger to the operators and the environment.

WARNING: Pumps that have not been properly remediated or do not have a declaration of remediation will be rejected and returned to the sender carriage collect.

Date _____

TIMBRE AND SIGNATURE

⁴ TO BE COMPLETED ON THE CUSTOMER'S LETTERHEAD

9.4 CE CERTIFICATE FOR HTT SERIES PUMPS

Declaration of conformity ⁵ (facsimile)
to the Machinery Directive 2006/42/EC

EC DECLARATION OF CONFORMITY

We declare under our sole responsibility that the pump:

Brand: GEMMECOTTI

Type:

Model:

Serial Number:

Year:

As described in the attached documentation, it complies with the Machinery Directive 2006/42 EC (ex 89/392/EEC - 91/368/EEC - 93/44/EEC - 93/68/EEC - 98/37 EEC) only when used with liquids communicated by the customer..... and for the characteristics required of the pump in relation to order No. of.....

If the pumped liquid and the required performance have not been communicated, and/or the pump is not used in accordance with its intended purpose or under reasonably foreseeable conditions, the customer assumes full responsibility for the use of the product improperly as specified in the warranty clause Mod. 1.11.4.

Compliance with these requirements is expressed through the marking



ENRICO GEMME
(General Manager)
Cesate, date

Signature

9.5 ATEX/CE Certificate for Zone 2 (facsimile)

⁵ In cases where the customer does not communicate the type of liquid used in the pump and the expected operating conditions, the EC Declaration of Conformity will not be issued and the customer will assume the responsibility and burden of providing for the Certification of the pump in its application.



EU Declaration of conformity

The magnetic drive pump type:

SN

Together with all the pumps series:
EM(-C-T-P) PP/PVDF
bearing the mark:

CE  II 3G Ex h IIB T6 Gc

models:

EM-C 6 PP/PVDF, EM-C 10 PP/PVDF, EM-C 15 PP/PVDF, EM-C 31 PP/PVDF, EM-C 40 PP/PVDF, EM-C 50 PP/PVDF, EM-T 2000 PP/PVDF, EM-T 3000 PP/PVDF, EM-T 5000 PP/PVDF, EM-T 7000 PP/PVDF, EM-T 9000 PP/PVDF, EM-T 12000 PP/PVDF, EM-T SP 5000 PP/PVDF, EM-T SP 7000 PP/PVDF, EM-T SP 9000 PP/PVDF, EM-P 100 PP/PVDF, EM-P 200 PP/PVDF, EM-P 300 PP/PVDF, EM-P 400 PP/PVDF, EM-P 600 PP/PVDF, EM-P 800 PP/PVDF

have been manufactured by GemmeCotti s.r.l. in accordance with the following EC directives:

2014/34/EU (ex 94/9 EC), 2006/42 EC

and the following standards:

EN 12100, EN 13857, EN 809, EN 1127-1, EN 80079-36, EN 80079-37

The manufacturing process is internally controlled by a Quality Management System according to ISO 9001:2015 standards and the internal control of production file n. 101 ext. 01/07, is deposited at CESI, notified body N.0722.

This declaration of conformity is issued under the sole responsibility of the manufacturer.



ATTENTION: the above magnetic drive pumps, considered as components, comply by design with the directive providing that installation is correctly performed by the manufacturer of the machinery. The pump must not be put on duty until the machinery or plant into which it has been incorporated is declared in conformity with the Machinery Directive. This declaration does not imply any warranty of properties. The safety instruction of the accompanying product documentation shall be observed.

Since there is an endless variety of products and chemical compositions that can be suitable to be processed by the considered devices, the end user is the only responsible to verify the reactions and suitability with materials used to build the pump. Therefore, all necessary tests and checks must be performed with great care to avoid any risk, and any adverse event that cannot be foreseen by the manufacturer and of which the manufacturer cannot be held responsible. Every dispute lies within competence of Varese Court.

Enrico Gemme
General Manager

Cesate, Date: _____



Via Po 23-25-27 - 20031 - Cesate (MI) ITALY - EU

www.gemmecotti.com

Tel. +39 02 96460406 - info@gemmecotti.com

Mud 4.2.11(CTP)