



PUMPS HTM SP PP **EM-C PP/PVDF PUMPS (ATEX ZONE 2 VERSION)**

Magnetic drive self-priming centrifugal pumps in thermoplastic material



INSTALLATION MANUAL, USE AND MAINTENANCE

Translation of the Original version

(SAFETY INSTRUCTIONS)

INDEX

1. INTRODUCTION.....	5
1.1 General	5
1.2 Purpose of the Manual.....	5
1.3 Safety Alert Symbols	5
1.4 Qualification and training of operators	5
1.5 Environment with danger of explosions	6
2. INSTALLATION.....	6
Introduction	6
2.1 General safety warnings	6
2.1.1 Introduction on the danger.....	6
2.1.2 Hazard information	6
2.2 Receipt and Inspection.....	8
2.3 Storage.....	8
2.4 Installation.....	8
2.5 Hydraulic system	9
2.6 Pipes Connection	9
2.7 Monitoring equipment	9
2.7.1 Checking the pump in ATEX ZONE 2 explosive environments.....	10
2.8 Motor connection.....	11
3. OPERATION	12
3.1 Use and safety.....	12
3.2 Dry running	13
3.3 Temperature.....	13
3.4 Before starting	13
3.5 Start-up	14
3.6 Optimal conditions of use	15
3.7 Shut down.....	15
1. 3.8 Long pump inactivity.....	15
3.9 Noise level.....	15
4. MAINTENANCE	16

4.1	General provisions.....	16
4.2	Inspections.....	16
4.3	Procedure before disassembly.....	17
4.4	Main parts.....	19
5.	PUMP DISASSEMBLY	20
5.1	Disconnection of the pump from the motor	20
5.2	Disassembling Pump Components	21
5.3	Internal disassembly of the pump	21
5.3.1	Inner Magnet Assembly Disassembly.....	21
5.3.2	Disassembling the Diffuser Group	22
6	PUMP REASSEMBLY.....	23
6.1	Warnings.....	23
6.2	Special Notes.....	23
6.3	Replacing the motor.....	24
6.4	Tightening torques.....	24
7.	PROBLEM SOLUTIONS	25
8.	SPARE PARTS	26
8.1	Accessories for the HTM series	26
8.1.1	Flanges	26
8.1.2	Baseplates.....	26
8.1.3	AI-13Y –Dry Running protection Device.....	26
8.2	Spare parts and kits	26
8.3	How to order spare parts and accessories	27
9	DATA.....	28
9.1	Characteristic curves.....	28
9.2	HTM 31 SP DIMENSIONS.....	28
10	WARRANTY AND REPAIR	29
10.1	Warranty.....	29
2.	9.2 Returned parts and repair.....	31
10.3	Decontamination Declaration (facsimile).....	32
10.4	CE CERTIFICATE FOR PUMPS SERIES HTM PP/PVDF	33
10.5	ATEX/CE certificate for zone 2 (facsimile).....	34

1. INTRODUCTION

1.1 General

This manual refers to the family of magnetic drive centrifugal pumps of the HTM SP Self-priming model. The pumps of this family are built in thermoplastic material Polypropylene or PVDF (pump body available only in PP) and in different sizes. The dimensions and powers available are described in paragraph 9.0.

1.2 Purpose of the Manual

The primary purpose of the manual is to ensure that the installation, use and maintenance activities of the pumps are carried out correctly and safely by the various operators responsible for these operations. The document also provides the customer with useful information for diagnosing problems, finding spare parts and accessing the repair service offered by GemmeCotti srl

ATTENTION: check on the website www.gemmecotti.com if subsequent revisions to this manual have been released.

1.3 Safety Alert Symbols



This symbol indicates possible dangers induced by the presence of electric fields, contacts or wires with electric voltage.



Exclamation point signals in this manual indicate a particularly important situation that requires attention from the operator. In particular, they are useful indications for correct operation and for the prevention of possible damage to the devices.



This symbol indicates the presence of strong magnetic fields that may damage or impair the operation of other devices if placed nearby. SUCH AS PACEMAKERS, QUARTZ WATCHES, DIAGNOSTIC EQUIPMENT ETC. SEE SECTION 2.1.2 FOR MORE DETAILS



This symbol indicates a danger or a situation which requires the utmost attention on the part of the operator. It is essential to respect the instructions given on the sidelines of this symbol and to proceed with the utmost caution. It is necessary to inform all operators and/or users that the rules indicated prevent accidents.

1.4 Qualification and training of operators



The personnel responsible for the installation, use and maintenance of the pumps must be qualified to carry out the operations indicated in this manual. GemmeCotti cannot be held responsible for the insufficient level of preparation and training of the customer's personnel and for the fact that they were not made aware of the contents of this manual. It is essential to always provide this manual to the operators assigned to install, use and maintain the pump. Keep this manual in a safe place for future reference.

1.5 Environment with danger of explosions

The pumps described in this manual cannot be used in environments with danger of explosions. For this type of use, special pumps built by GemmeCotti with particular materials and devices are required. The customer who intends to use special pumps in this type of environment must consult the GemmeCotti technical office for a correct choice of the article.

The pump models, built by GemmeCotti, for this type of applications are distinguishable by the acronym EM-CO or EM-C or EM-T or EM-P.

Model EM-C, EM-T and EM-P pumps in PP or PVDF can only be installed in ATEX zone 2 group II category 3 G Ex h IIB T6 Gc. Refer to paragraph 2.7.1. for more information.



WE REMIND YOU THAT THE CLASSIFICATION OF THE ZONE (REF. ATEX 2014/34/EU FORMER 94/9/CE DIRECTIVE) FOR POTENTIALLY EXPLOSIVE ATMOSPHERE ZONES HAVE TO BE DONE BY THE CUSTOMER AND COMMUNICATED TO GEMMECOTTI FOR THE RIGHT CHOICE OF THE TYPE OF PUMP SUITABLE TO WORK IN THESE ZONES.

It is also the customer's responsibility to correctly install the pump in accordance with the requirements set out in the Directive

2. INSTALLATION

Introduction

All references made to pumps are considered applicable to systems using these pumps unless otherwise specified.

2.1 General safety warnings ¹

2.1.1 Introduction on the danger



ATTENTION : Failure to observe the indications given in this manual or the improper use of the equipment by unqualified and unauthorized personnel could cause serious personal injury or death and damage to products and things!

The technical assistance service is at your complete disposal; for any doubts or problems, you can contact us by telephone on +39 02 964.60.406 or write an email to info@gemmecotti.com . We strongly recommend that you keep GemmeCotti's written response.

2.1.2 Hazard information



For the safety of the operators involved in the installation operations, it is necessary to use protective clothing and personal protective equipment approved in accordance with the provisions of the law in force (ie safety goggles, gloves and insulating and protective footwear against crushing).

¹ Failure to comply with the warnings provided may invalidate the pump's Certification and Warranty



The pump contains particularly powerful magnets. It is forbidden for personnel with cardiac pacemakers, defibrillators, electronic medical devices, metal heart valves, metal prostheses or sickle cell anemia to handle or be in the vicinity of the magnets contained inside the pumps. Consult an occupational physician for specific recommendations before working with these pumps.



The strong magnetic fields present near the pumps can damage heart pacemakers, watches, credit cards, magnetic disks and tapes present inside calculators and computers.



When working near the pumps, consider that the tools or metal parts handled may be suddenly attracted towards the body of the pumps, causing possible crushing of fingers or hands.



These pumps have been designed and built for use in specific conditions and within defined limits. Use outside these specifications must be agreed and approved by the GemmeCotti technical service. **It must be kept note that, if the pumps are used outside their technical specifications, the CE Certification and the Warranties are void. Furthermore, if the pump is used outside the technical specifications communicated in the estimate phase and confirmed with our order confirmation, the user assumes all responsibility for the CE certification of the product.**



The pump must be used only in the applications, conditions (temperature, pumped liquid) and characteristics (flow rate and head) specified in the gemmecotti proposal and confirmed with the order confirmation, for which gemmecotti has selected the model, the construction materials and tested the pump to comply with its specifications. For any use other than what is communicated with the order confirmation, a written request must always be made to the technical department of gemmecotti which in turn will respond in writing.



No guarantee is provided for repairs or alterations made to the product by users or by third party personnel not specifically authorized by GemmeCotti.



Always stop the pump before touching it or carrying out any work on it or in the installation circuit.

Make sure that the electrical network to which the pump will be connected has adequate power and has the correct protection devices (ie earthing, circuit breaker).

Always disconnect the power supply before working on the pump for maintenance or replacement of parts.



Always keep a fire extinguisher near the pump installation.

Always use extreme caution when performing maintenance tasks on pumps and attached circuits when used with hazardous liquids. **PERSONNEL WHO INTERVENE MUST BE PROPERLY TRAINED ON POTENTIAL HAZARDS**



The use of an electric starter is recommended. A simple switch may not be sufficient to start

and stop the electric motor connected to the main power line. An appropriate starter:

- allows you to prevent accidental starts after a failed start attempt;
- provides a safe switch, protected against water;
- protects the electric motor against short-circuit overloads (a fuse only protects the wires);
- resists overloaded starts on the motor, preventing dangerous arcing and premature wear of the electrical contacts.

2.2 Receipt and Inspection

Although all precautions have been taken before packing, we advise you to carefully check the material received. Review all items on the packing list. Make a written report immediately for any damage or shortages attributable to the carrier and/or GemmeCotti.

Check the plate data of the pump received and compare them with those relating to your purchase order.

If the pump came with the motor, remove the motor fan shield and try turning the motor shaft by hand. If you feel strong resistance to rotation or if you hear abnormal noises, call your trusted dealer or the GemmeCotti assistance service directly.

2.3 Storage



If the pump is placed in the warehouse, make sure that this takes place in a dry and sheltered place; always use the original packaging or equivalent protection. Should the pump be left in the warehouse for very long periods and/or in particularly humid environments, the use of hygroscopic substances (silica gel) is recommended to prevent damage.



Do not remove the flange protections until installation and close, if not already closed, the holes of the intake/delivery manifolds and the air connection to prevent the intrusion of foreign bodies.



It is warned that a prolonged storage time of the pumps can cause:

- degradation of motor insulation due to moisture absorption
- seal degradation

After prolonged storage, before commissioning, it is a good idea to check the tightness of all the bolts of the pump and between the pump and the electric motor. Check for oxidation of the electrical contacts in the motor box

2.4 Installation



GemmeCotti srl cannot be held responsible for damage to persons or objects caused by improper installation or by unqualified personnel.

Install the pump in a location that allows for easy service.



The motor/pump unit must be fixed to a rigid structure which allows the entire structure to rest. Make sure that the pump is fixed on a surface, if necessary use the bases supplied by GemmeCotti or wedges under the motor support bases. Where deemed necessary, use "bumpers" to reduce vibrations towards the fixing surface.

The pump must be installed horizontally. if the pump is not installed horizontally, it cannot work

2.5 Hydraulic system

The pump is generally part of a hydraulic system which may include a number of components such as valves, fixtures, filters, expansion joints, tools, etc. The way the system is made and the positioning of its components has a great influence on the operation and life of the pump.



It is advisable to wash the newly built systems internally before installing the pump to remove any processing residues to prevent them from entering and damaging it.

2.6 Pipes Connection ²

Locate the pump as near as possible to the liquid source and under the level of the liquid (under head).



Always use pipes as short and straight as possible and limit the number of bends assuring radius of curvature as large as possible. Avoid turbulence and air siphon that can be created in the long piping line. Avoid the creation of siphon also before the suction of the pump.



The pipes must be supported and kept in line independently from the pump, up to its connections, so as not to weigh on it.



The diameter of the suction hose must be equal to the diameter of the suction connection of the pump. The diameter of the discharge pipe must be equal to or greater than the diameter of the discharge connection. **Caution:** To allow the pump to be primed, neither the suction nor the discharge must be intercepted. Narrowing on the suction pipe is responsible for and causes cavitation of the pump, leading to a loss of efficiency and rapid wear. It is recommended to always use reinforced hoses that do not collapse in a vacuum situation. **THE DISCHARGE MUST BE FREE WITHOUT SHUT-OFFS TO ALLOW THE PUMP TO BE VENTED DURING PRIMING. IF THIS DOES NOT HAPPEN, THE PUMP WILL NOT WORK.**



The liquid to be pumped must be free from slag or foreign particles.
Never couple metal pipes to plastic pumps.

Tightening the pipes on plastic pumps must be done without the use of tools.

Make sure that the connections are carefully tightened and watertight otherwise the suction capacity will be reduced.

A vacuum gauge should be installed on the suction pipe near the pump, while a pressure gauge should be installed on the delivery pipe. The installation of these tools will allow the operator to easily check the correct functioning of the pump in relation to the required operating point. In the event of cavitation or other malfunctions, noticeable pressure fluctuations will be observed.

2.7 Monitoring equipment

Depending on the importance of the pumping circuit, it may be useful to maintain close control over the performance and conditions of the process. The use of instruments for measuring

² Failure to comply with the warnings provided may invalidate the warranty terms on the pumps supplied.

pressure on the suction and discharge circuits may be recommended.

The measurement of the electrical power absorbed by the motor can also be measured by means of the use of a wattmeter.



If the temperature of the pumped liquid can represent a critical element, insert a thermometer in the circuit, preferably on the suction line.

These control instruments can warn of any anomalous pump operating situations such as: accidentally closed valves, missing liquid, overloads, etc.

Caution: the pump will not prime if the suction and/or discharge lines are intercepted. before commissioning the self-priming pump, check that the suction piping and the connections to the pump are watertight. the outlet must be open without shut-offs to allow the evacuation of the air in the intake which allows priming

2.7.1 Checking the pump in ATEX ZONE 2 explosive environments

In addition to respecting the general warnings stated in this manual, special pumps used in potentially explosive areas have to be installed with control equipment specified in this paragraph to maintain a strict monitoring of the performances and process conditions. The control equipment mounted near the pump has to be certified for the same hazardous zone as the pump installed unless it's protected by an airtight closure cabinet also certified

The installation of pumps type EM-(C-T-P) for use in potentially explosive areas has to follow the rules stated in the ATEX Directive 2014/34/UE.

In particular the requirements referred to the manufacturer applicable to apparatus of **Category 3 of Group II** (explosive atmosphere due to gas, vapours or mists presence) are the following:

- the devices have to be designed and manufactured so that they avoid trigger sources predictable during normal functioning.
- During expected functioning conditions, the surface temperatures must not exceed the maximum temperatures indicated (paragraph 3.1). An eventual overcoming is endurable, in exceptional cases, if the manufacturer adopts extra special protections.

The temperature classes are as follows:

Temperature classes according to ISO80079-36	Liquid temperature limits
T6 (85°C)	60°C
T5 (100°C)	75°C
T4 (135°C)	110°C
T3 (200°C)	175°C

- Ambient temperature should be between -20°C and 40°C as per ISO 80079-36
- Fluid temperature has to be measured at the suction port
- Attention: the chart with the range of temperature is valid only in optimal conditions of use of the pumps (rpm, capacity, head and NPSHa), with correct lubrication and maintenance.
- In any case, the fluid temperature must not exceed the pump's maximum or minimum design temperature (see section 3.1)



It is not recommended to mount the suction filter to avoid obstruction to the suction of the pump which can cause cavitation and/or dry running. A suction filter can only be useful during

the start-up phase, for cleaning the same and in any case it must be monitored to avoid clogging that would lead to the correct operation of the pump



If unacceptable working conditions are revealed, the pump has to be automatically stopped and checked



NPSHa can decrease in case of installation of a valve in the suction line. In this case, it is necessary to install a flowmeter to check possible variations.



The pump is equipped with a conductive ring and so with an accurate ground connection of the ring there can't be unwanted electrostatic charges, sources of explosion trigger.



Pumps supplied for ATEX zone 2 must be coupled to suitable Ex-proof motors.

2.8 Motor connection



Check that the voltage and frequency shown on the motor label correspond to those of the electrical network you are to use.

Never connect the electric motor directly to the main line but protect the dedicated line with a suitable main switch with adequate safety and overload protections.



Electrical connections must always be carried out by a qualified expert electrician. Check the voltage, number of phases on the motor plate and proceed accordingly with the adequate electrical connection. The type of connection in three-phase motors can be star (\square) or delta (Δ) according to the 400 or 230 VAC power line (see figure 1).



Figure 1



Make sure that the sense of rotation of the motor is that specified on the pump head and eventually indicated by a sticker arrow on the motor fan; to change the sense of rotation it's sufficient to change two of the three entering line (E.g . L1 with L2) in three-phase motors.



Read the following instructions to change the sense of rotation:

- wear approved personal protective equipment (i.e. glasses, gloves)
- ensure that the conditions of use comply with the pump specifications (see paragraph 7)
- install the pump in the hydraulic system
- fully open the suction and discharge lines. **Warning** : The suction and/or delivery line

- must not be intercepted otherwise the pump will not prime.
- Fill the pump body with the first filling liquid. **Warning** : the pump will not prime if the pump body is not filled from the cap up to its hole . It is advisable to carry out this test with an inert liquid such as water, if compatible with the process.
 - never allow the pump to run dry (NB the design of the pump with magnetic drive does not allow dry running as this would irreparably damage the internal components of the pump)
 - power the motor only for one or two seconds to observe the direction of rotation which complies with the arrow placed on the motor and on the pump and indicated on the technical drawings of the pumps. (clockwise looking at the front of the pump and counterclockwise looking at the motor fan)

NOTE: A pump running in the opposite direction will still pump but with a flow and pressure much lower than the data on the plate. If a direction of rotation opposite to the expected is detected, reverse two of the three input lines as described above

3. OPERATION

3.1 Use and safety

ATTENZIONE:

Dangerous or hazardous actions can cause serious injuries or death to people or serious damage to materials and so it's important to assure the respect of all the warnings relative to the safety and the correct use written in this manual



Always check that the fluid being pumped is compatible with the construction materials of the pump. For any clarifications, contact the GemmeCotti technical office.



When used for pumping aggressive, toxic or health-hazardous liquids, it is generally necessary to install on the pump adequate protection for the containment, collection and signaling of the dangerous product in the event of leakage: Ex. POLLUTION DANGER , CONTAMINATION, INJURY AND/OR DEATH.



Due to the materials of which the pumps are made, there is the possibility of the onset of electrostatic charges which must be dissipated by means of suitable earthing.



Do not pump liquids containing solids in suspension. Mag drive pumps are designed to pump clean liquids. It is NOT recommended to mount the filter on the suction line to avoid obstruction of the suction of the pump which can cause cavitation and/or dry running. A suction filter can only be useful in the start-up phase of the system, for cleaning it, and in any case it must be monitored to avoid blockages which would lead to the incorrect functioning of the pump. Avoid, in particular, pumping liquids containing ferro oxides or other ferromagnetic particles, even if small. If you are in doubt, please call GemmeCotti technical service (tel. +390296460406).



Never restrict the suction. Restrictions on the inlet are responsible for pump cavitation, which leads to a loss of efficiency and rapid wear. Restrictions on the delivery are not advisable, reductions in the flow rate, if required, can be obtained by means of a valve installed on the delivery pipe.



Never loosen the pump connections while it is under pressure.

Do not start and/or operate the pump if there are traces of leaks in the circuit.

The operating temperatures must be such as to respect the characteristics of the construction materials used in the pump:



- 0- 60 °C execution in polypropylene (PP)
- 0- 80 °C execution in PVDF



DO NOT ALLOW THE PUMP TO RUN DRY (note: the mag drive pump design doesn't allow the dry-running functioning because it will damage irrevocably the inner parts of the pump)



An accidental failure can generate spray up to a considerable distance.



In the event of abnormal vibrations or noises, stop the pump immediately.



Do not pump flammable liquids.



Do not touch the pump while it is running.



Switch off the power before touching the motor or lantern.

3.2 Dry running



Fill the pump with water (if compatible with the process liquid) or with the liquid to be pumped before starting it. This will protect the bushings and pump shaft against dry running. **NEVER RUN THE PUMP DRY** as serious damage can be caused due to lack of the necessary lubrication to the internal components of the pump itself.

3.3 Temperature



Increasing the temperature of the fluid moved can damage the pump and/or the system pipes and can cause a situation of serious danger for people in the vicinity. Avoid sudden jumps in temperature and do not exceed the temperatures specified in the order, or the limits shown in the technical data sheets available on the web page. See the temperature values of the pump construction materials in paragraph 3.1.

3.4 Before starting

Be sure that the pump is installed in accordance with the instructions given in section 2 above.



Attention: The pump body must be filled with liquid to allow priming. The suction and delivery pipes must never be intercepted otherwise the pump will not prime

ATTENTION: ALL THE PUMPS ARE TESTED WITH WATER, it is therefore possible that there are small residuals of water; if the **LIQUID TO BE PUMPED IS INCOMPATIBLE WITH WATER**, or if the **SYSTEM** where the pump is installed **COULD BE DAMAGED** by the presence of water, **IT IS NECESSARY TO ACCURATELY DRY THE PUMP WITH AIR AT A TEMPERATURE NOT HIGHER 35°C.**

3.5 Start-up

Make sure that the pump body has been filled with water up to the filler cap. If the water is not compatible with the process, provide for filling with a compatible inert liquid having the same specific weight and viscosity characteristics as water. Once the pump has been filled, tighten the filler cap with the relative OR and make sure that it is watertight.

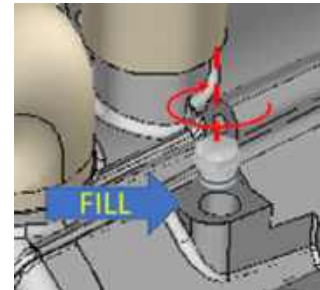

Make sure that the suction and discharge pipes are not intercepted otherwise the pump will not prime. The delivery pipe must be connected to a container whose pressure is the same as that of the container for the liquid to be sucked in. Higher pressures in the delivery container do not allow the air to be evacuated from the suction pipe, not allowing the priming of the pump, when the two tanks must be put in communication.

In the case of suction tanks at atmospheric pressure, the delivery pipe must be connected to an open container with the atmosphere. If the delivery vessel is closed, it will be under slight pressure during the priming phase, inhibiting the priming of the pump.

Make sure that the suction line is as short as possible and vertical.

The priming of the pump has physical limits, due primarily to the atmospheric pressure and the temperature of the liquid to be pumped. The atmospheric pressure decreases as the altitude at which the pump is installed increases.

By way of example, the pump at sea level with water at 15 degrees can be primed up to a height of 6-7 meters. The same pump, mounted on a plant in a mountainous area at an altitude of 2000 meters, will be adapted to much lower heights. Contact the gemmecotti technical office for more information.

Start the electric motor and check the correct direction of rotation of the motor

Check the priming times with the graph at the end of this manual.



Warning : Liquids with a specific weight greater than 1Kg/dm³ and altitudes higher than sea level lengthen the priming times compared to those shown in the graph.

With primed pump, if the pressure indicated by the outlet control instruments does not increase, switch off the pump immediately and release the pressure gradually.

Carefully check the tightness of the entire suction part of the pump (suction pipes and fittings, pump suction pipe connection, filler cap)



Attention: The suction pipe must be at least 50cm below the free surface

Once the above checks have been carried out, repeat the pump starting operations.

If during the start-up phase there are changes in the flow velocity, density, temperature or viscosity of the liquid, stop the pump and contact with the technical assistance service of GemmeCotti srl.

3.6 Optimal conditions of use

Operating continuously at the far end right side of the pump performances curve (maximum pressure with valve fully closed or maximum flow rate with valve fully open at the bottom of the curve) there can be an early wear of the pump. As a general rule, we recommend using the pump at half of its maximum capacity (see the paragraph relative to the technical data)
In any case do not allow the pump to work out of curve.



The characteristic curve of the pump, showing flow rate and head, refers to pumping of water at room temperature. If liquids at high temperatures or high viscosities and densities have to be pumped, the performances must be correspondingly reduced. The HTM series pumps work well with liquids having viscosities up to 100 CPS and specific gravities up to 1.9 kg/dm³. **IN ANY CASE BOTH THE VISCOSITY AND THE SPECIFIC WEIGHT MUST BE COMMUNICATED DURING THE QUOTATION REQUEST PHASE**, the electric motor is selected for the communicated viscosity and specific weight, if they are higher, the engine power could be insufficient.

3.7 Shut down

Normally the pump should be shut down only after closing the delivery valve. If the suction valve is closed before the other, cavitation of the pump can occur.

If the suction is under swing (flooded), close the valve after shutting down the pump.



In some cases the pump can be used to empty tanks, in these situations the liquid can stop flowing in the pump while this is still working. In these cases a pump operating without liquids (that means dry-running) can be dangerously damaged if it's not stopped immediately. For such applications the use of automatic equipment or the constant presence of a person who can shut down the pump is recommended.

1. 3.8 Long pump inactivity



If the pump has to remain inactive for a long period, before stopping it, it's recommended to let water flow in the system for several minutes so that you avoid any risk of internal deposits or sediments or precipitations of solid parts. Drain the liquid in the pump. An eventual freezing of the liquid inside the pump can cause damage. Always verify if the pumped liquid reacts with water. In this case contact GemmeCotti to find an alternative solution

In cases where the pump is temporarily removed from the system and stored, the instructions provided in paragraph 2.3 "Storage" must be followed.

3.9 Noise level

In some circumstances, for example when the pump works with high pressure and low flow rate, the noise increases and can be annoying for the personnel working nearby. In this case it is possible to intervene with:



- Earplugs;
- approved protective ear defenders ;
- soundproofing devices for the pump. In these cases, make sure that the motor ventilation is guaranteed .

4. MAINTENANCE

4.1 General provisions



During the warranty period, no extraordinary maintenance operations on the pump must be performed except by GemmeCotti personnel or those authorized by GemmeCotti. All the operations described in the following paragraphs must only be carried out by suitably qualified personnel and following all the warnings included in this manual step by step.

In case of routine maintenance of the pump (as indicated in paragraph 4.2) the customer is responsible for the correct disassembly and assembly. The pump warranty is void in the event of tampering with it, use of non-original parts or in the event of practices that do not comply with the instructions in this manual.

During ordinary maintenance of the pump, the customer is responsible for checking the seals (via hydrostatic test, taking care to respect the PN - nominal pressure - of the pump), impeller/magnet alignment, positioning of the shaft, assembly of bushes and control of good functioning of the pump. To tighten the screws, refer to the values given in paragraph 6.1 and be careful not to pinch the O-ring.

Clean the external surface of the pumps using antistatic devices only.



Any operation carried out on the pump must be carried out only after having physically disconnected the power supply.



Handling of pumps weighing more than 16 kg must not be done manually, but only using hoists or other suitable means. When moving the pump or parts of it, avoid blows or falls that could damage the devices.



Before proceeding to disassemble any parts of the pump, make sure that the dangerous internal liquids have been properly removed / flushed out. **THE PUMP MUST BE CLEANED.**



Pay attention that some internal liquids could have dangerous reactions in contact with water.



When discharging dangerous liquids, make sure that there are no dangerous situations for people or the environment.

4.2 Inspections

In general, magnetic drive pumps do not require frequent maintenance or disassembly. However, periodic inspections are advisable to check the state of wear of the impeller, shaft, o-rings and bushings and if the general conditions of the internal parts of the pump are good.

The inspection interval strongly depends on the operating conditions of the pump, on the characteristics of the fluid, temperature, materials used and of course on the operating time.

After the first start-up it is advisable to check the bushings after 3 months. If the check is successful, it is advisable to carry out a further check after another 6 months. The next inspection is recommended after one year of operation (about 2000 hours). In any case, it is good practice to replace the PTFEC bushings every 2000 hours of pump operation.

The other components should only be changed when they show clear signs of wear.

If a problem has been found or the pump needs a complete inspection see the chapters “Troubleshooting” and “Pump disassembly”.

4.3 Procedure before disassembly



ATTENTION:

If the pump has pumped hot liquids, make sure it has cooled down before proceeding with disassembly. The pump may have pumped toxic and/or dangerous liquids: it is therefore necessary to wear skin and eye protection.



ATTENTION:

Be sure you have thoroughly purged the pump. Thoroughly flush and neutralize hazardous fluids inside the pump. The liquid must be recovered and disposed of according to existing environmental laws. After having disconnected the suction and delivery pipes, close the ends.

**ATTENTION:**

GemmeCotti pumps contain extremely strong magnets. The use of non-ferrous magnetic tools and worktops is highly recommended.

Beware of strong magnetic attraction when disassembling / reassembling the pump motor-outer magnet assembly.



The area where maintenance is performed must be clean and free of ferrous particles which can be attracted to the magnets.

**ATTENTION:**

Wearers of PACE MAKER or equivalent devices cannot operate on the pump or near it due to the presence of strong magnetic fields.

**ATTENTION:**

It is recommended not to operate near the magnets wearing wrist watches, bracelets, rings and ferromagnetic jewels and/or with electronic equipment sensitive to magnetic fields .

4.4. Main parts

The attached drawing shows an exploded view of the constituent parts of the HTM 31 SP PP pump in thermoplastic material.

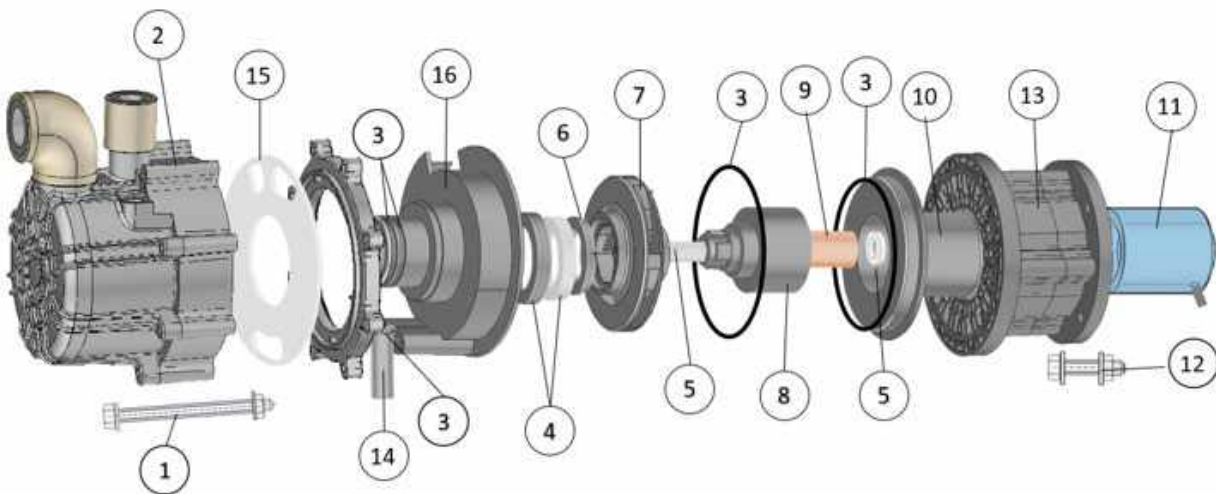
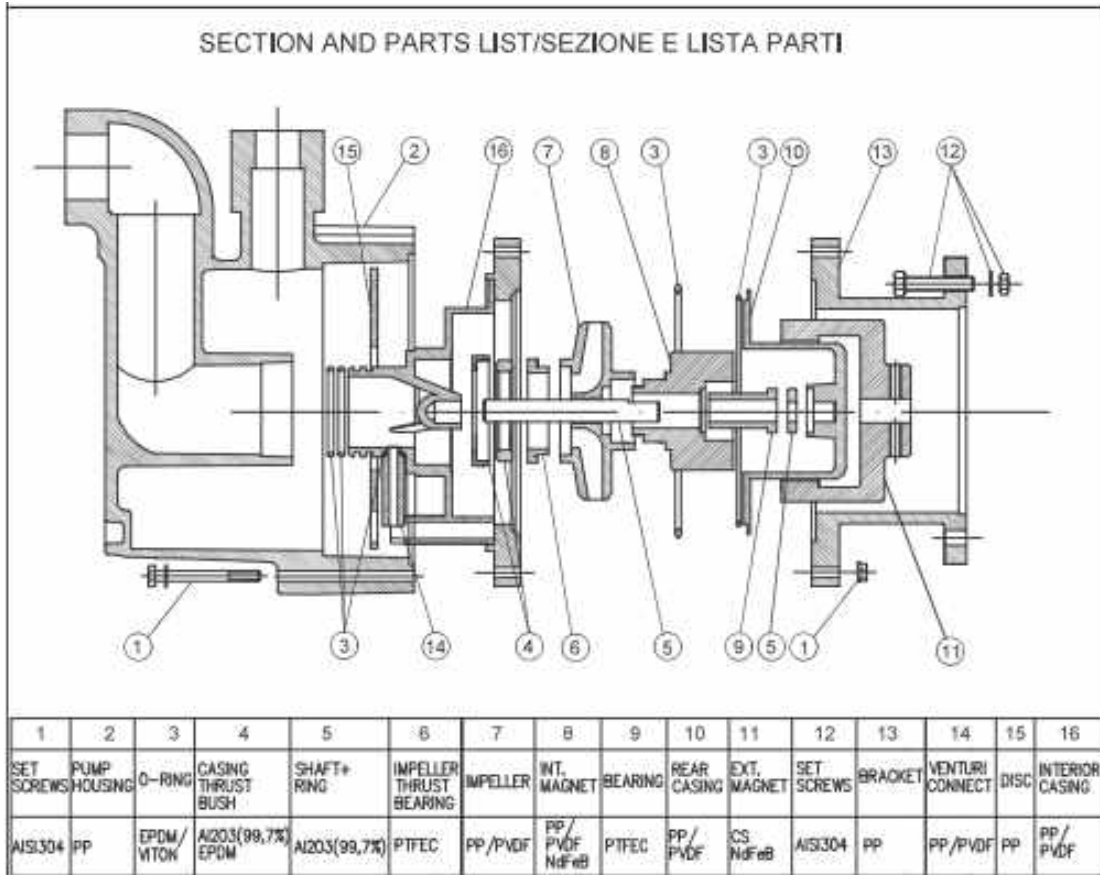

5. PUMP DISASSEMBLY

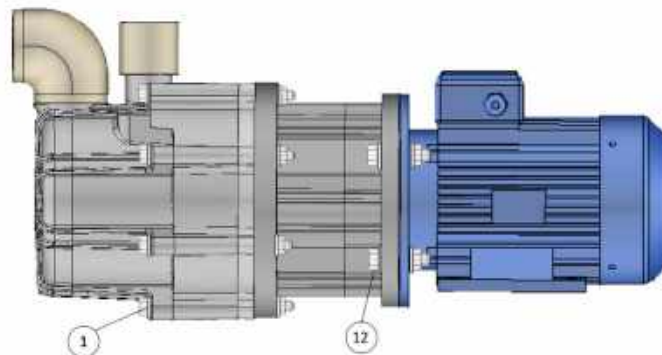

5.1 Disconnection of the pump from the motor

Sequence of operations:

1. After removing the fastening screws between the pump and the motor (12), remove the motor with the attached external magnet keyed to the motor shaft.

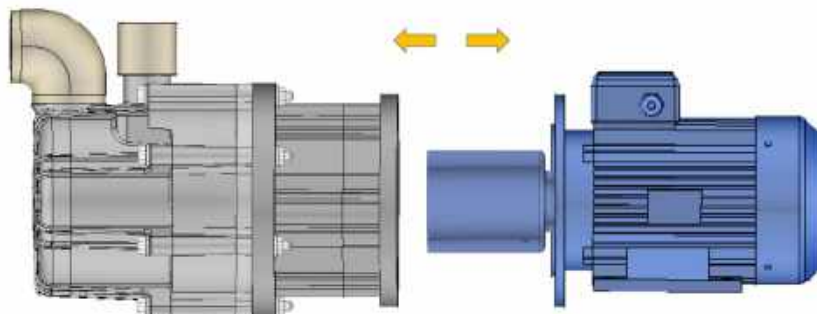

2. If it is necessary to remove the external magnet from the motor shaft, proceed by unscrewing the grub screws with an Allen key and then use a puller to avoid damaging the motor shaft and/or the external magnet.

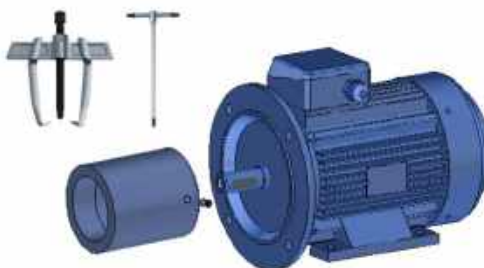

5.2 Disassembling Pump Components

After removing the tightening screws (1), separate the inside of the pump from the lantern and from the pump body

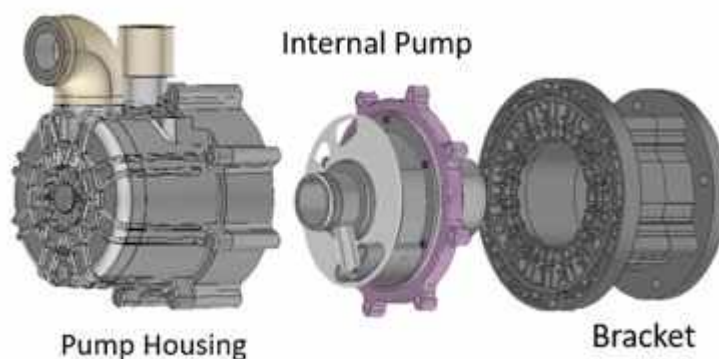

5.3 Internal disassembly of the pump

Separate and disassemble the **Inner Magnet Assembly** and **Diffuser Assembly** separately



5.3.1 Inner Magnet Assembly Disassembly

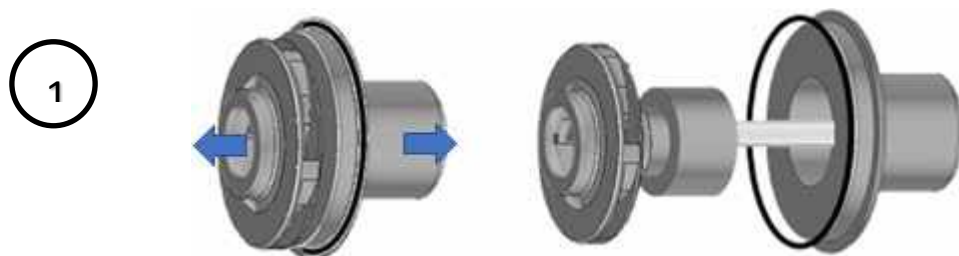

1) Extract impeller and internal magnet from the cup and remove O-RING (3)

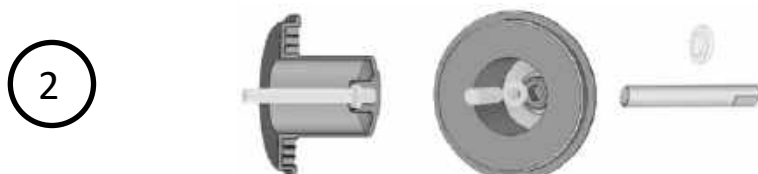

2) From inside the cup, extract the ceramic shaft with its rear ceramic washer (5)

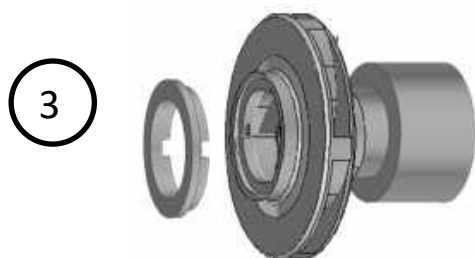

3) Remove the front wear ring (6) from the Inner Magnet Assembly



Be careful that the shaft and the washer are made of ceramic material and therefore very fragile.

The components that must be periodically checked and possibly replaced are:

- O-rings (3)
- Shaft and washer (5)
- Front wear ring (6)
- Rotating bushing (9) inside the internal magnet

5.3.2 Disassembling the Diffuser Group



- 1) Remove by unscrewing the Venturi tube and its O-ring (14)
- 2) Remove the O-rings (3) from the diffuser



1. Remove the Separator Disc (15) by lifting it

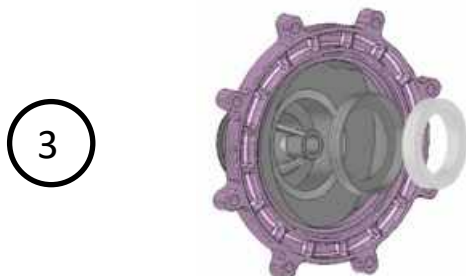

1. From the back of the Diffuser, remove the ceramic sealing ring with its elastomer cap (4)

6 PUMP REASSEMBLY

The assembly sequence mirrors the disassembly sequence, however the following warnings must be kept in mind:

6.1 Warnings



ATTENTION:

Thoroughly clean each component before assembly, make sure that all parts are free of dirt, metal particles etc. Replace all O-rings



- always check that the bushes are seated correctly and if necessary use a manual press to insert them completely in their seat;
- make sure that when the pump is closed, the gaskets (o-rings) are perfectly in place and are not pinched.



- when inserting the pump onto the motor, pay attention to the magnetic attraction force which can cause damage to fingers or hands.



- use torque wrenches for a correct tightening torque of the screws in accordance with the values given in paragraph 6.4
- after having tightened the pump on the motor flange, momentarily remove the protective shield of the impeller on the rear of the motor and rotate the impeller by hand to check the free rotation of the assembly thus created. If excessive friction or anomalous noises are detected, proceed with the disassembly of the assembly (operations in paragraph 4.4) and eliminate the cause of the anomaly. Under no circumstances proceed to use the pump without having carried out this check.

6.2 Special Notes



- If the external magnet has been disassembled, when reassembling it, due to slight interference between the motor shaft and the magnet, it may be advisable to slightly heat the hole in the magnet using a heat gun.

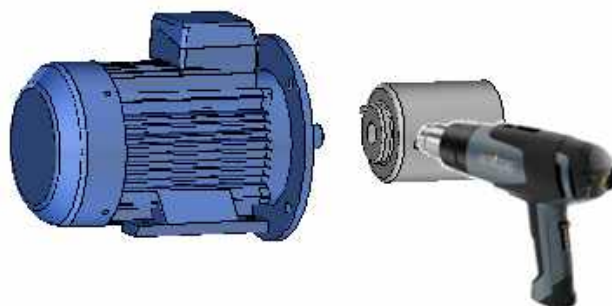

- When reassembling the separation disk (15), be careful to insert it in the right direction as highlighted in the figure

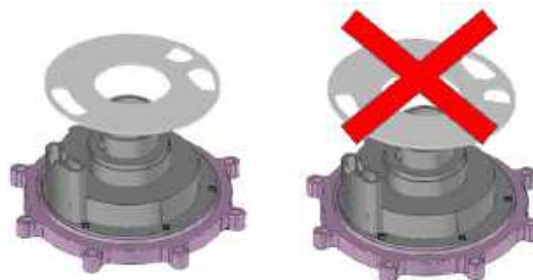

6.3 Replacing the motor

Proceed as indicated in the previous paragraph 5.1. Make sure that the characteristics of the motor are the same as the motor being replaced. The engine manufacturer may be different from the one previously fitted.

6.4 Tightening torques

Recommended tightening torques:

HTM SP PP/PVDF	HTM SP 31	
	screw	Nm
Motor/pump flange	M12	40/50
Pump housing/Bracket	M8	10/12

7. PROBLEM SOLUTIONS

1 Motor overload	2 Insufficient flow speed or pressure in the pump	3 No pressure on the delivery side	4 Irregular outlet pressure flow	5 Noise and vibration	6 Pump clogged	7 Pump overheating	8 Abnormal wear	9 Leak in the pump	10 Pump does not prime	Possible cause	Solution
	•								•	Wrong direction of rotation of the motor	Reverse the direction of rotation
	•	•	•	•					•	Insufficient suction (NPSHa)	Increase NPSH availability: <ul style="list-style-type: none"> • Increase the suction reserve (positive head) • Lower the pump • Increase the diameter . of the suction pipe • Shorten or direct the suction hose
		•							•	The pump is clogged	Clean the pump
	•		•	•			•		•	Cavitation	Increase the suction available NPSH
	•		•	•			•		•	The pump draws in air	Check that the joints of the suction pipes are tight
		•	•	•					•	The suction hose is blocked	Check the valves and filters on the suction line
	•			•						Delivery pressure is too strong	Reduce thrust by increasing the diameter of the pipes and/or reducing the number of valves or bends
•				•		•				Flow velocity too high	Reduce flow: <ul style="list-style-type: none"> • Partially close the delivery valve • Reduce the rotation speed
	•			•	•	•	•		•	Liquid temperature too high	Cool the liquid
								•	•	Wrong o-ring material for pumped liquid	Fit an o-ring of different material (contact us)
•				•	•	•				The impeller rubs	<ul style="list-style-type: none"> • Reduce the temperature • Adjust the distance between the impeller and the cup or body
				•	•	•	•			Foreign objects in the liquid	Use a filter in the suction circuit
		•							•	Closing of the intake side valve	Check and open the valve
	•									Delivery pressure too low	Increase pressure: <ul style="list-style-type: none"> • Install impeller with larger diameter (contact GemmeCotti)
									•	Impossible to vent	<ul style="list-style-type: none"> • Open the delivery and suction valves and create a connection between the delivery and the atmosphere • Eliminate foot or check valves in the suction and delivery pipes

8. SPARE PARTS

8.1 Accessories for the HTM series

8.1.1 Flanges



GemmeCotti pumps are usually supplied with threaded connections. Upon request, UNI EN and ANSI loose flanges with collars can be supplied with threaded flat stub.

8.1.2 Baseplates

For a perfectly horizontal installation of the pump. Available in three versions:



- TYPE “A” suitable for: IEC B3/B5 motors from size 56 to 71
- TYPE “B” suitable for: IEC B3/B5 motors from size 80 to 90 NEMA 56TC and 145TC motors.
- TYPE “C” suitable for: IEC B3/B5 motors from size 100 to 112 NEMA 184TC motors.

8.1.3 A1-13Y –Dry Running protection Device



Useful equipment to prevent costly pump breakdowns as it avoids dry running, overloaded operation off curve, working with closed delivery and blocked suction

8.2 Spare parts and kits



A complete series of spare parts is available at our warehouse and our distributors.

A series of both RWE and WE KITs are also available for the HTM series, which can be consulted on the website <https://gemmecotti.com/shop/>



8.3 How to order spare parts and accessories

To request accessories and spare parts, it is necessary to communicate the pump model, the size, the material, or the serial number, the year of construction and the number of the requested spare part. These references can be found directly on the pump plate and on the sectional drawings relating to the pump itself. If you do not have the sectional drawings, contact the GemmeCotti sales office (tel. +39 0296460406). ***Only for European Union countries*** it is possible to order pumps, spare parts and accessories via e-commerce on the site <https://gemmecotti.com/shop/>

9 DATA

9.1 Characteristic curves

Pumps in PP thermoplastic material
CURVES/CURVES 50Hz

CURVE 50HZ - 2900 RPM

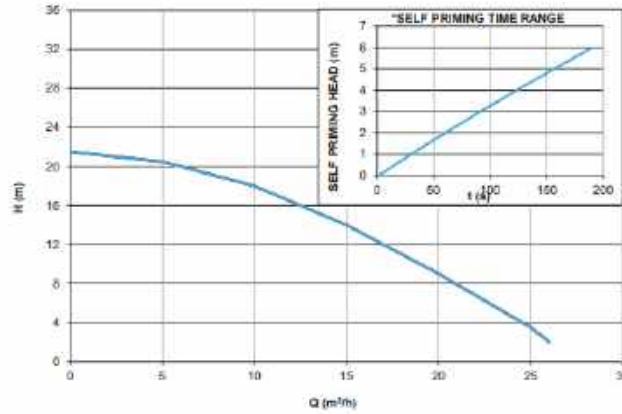

9.2 HTM 31 SP DIMENSIONS

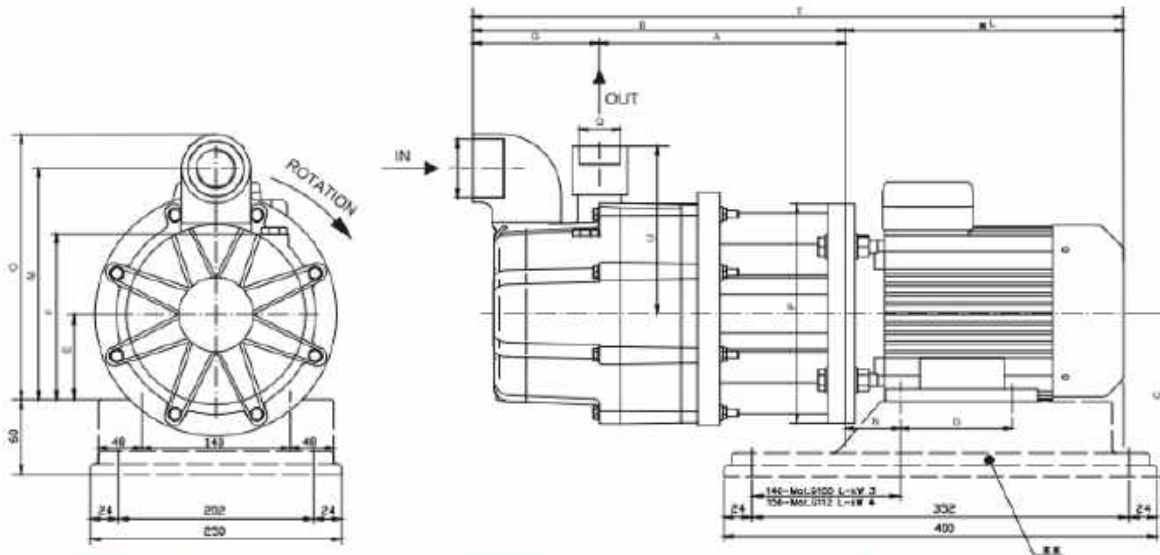

FOHFA	FLANGIA MOTORE (S)	P (KW)	DIMENSIONI - mm -															
			A	B	C	D	E	F	G	H	I	L	M	N	O	P	Q	T
HTM 31SP	Ø 100 L	3	280,5	425	160	140	100	181	144,5	17,5 (12mm)	317	285,5	83	304,5	250	175mm	142	100,5
HTM 31SP	Ø 102 H	4	280,5	425	160	140	100	181	144,5	17,5 (12mm)	317	285,5	83	304,5	250	175mm	142	100,5

* Diverso a seconda del fornitore di motori. ** OPTIONAL A RICHIESTA: Basamento e flange.
NOTE: DIREZIONE DI ROTAZIONE ANTIDIRARIA VISTA LATO VENTOLA MOTORE.

9.3 Technical data and limits

The performance curves are valid for homogeneous liquids with specific gravity =1, viscosity 1 cPs and temperature of 20 °C. If the liquid to be pumped has a specific gravity higher than 1, the absorbed power written on the performance curve has to be increased according to the value of the specific gravity of the liquid. For liquids having specific gravity higher than 2, please contact the GemmeCotti technical service (tel. +390296460406; e-mail info@gemmecotti.com).

The performance curves are valid for homogeneous liquids having viscosity of 1CPS. If the pumped liquid has a viscosity different from 1 CPS the values of Q/H will be altered. The performance of the pump will decrease. For liquids having viscosity lower than 0.5 CPS or greater than 100 CPS please contact the GemmeCotti technical service.

Values of required NPSH written on the performance curves are the lower required values. As a rule, for safety reasons, the value of NPSH of the system (NPSH available) should be at least 1 m higher than the value of NPSH required (written on the performance curves) to prevent lack of lubrication or dry-running with consequent damage of the bearings.

NPSHa can decrease with the installation of a valve bends, elbows, filters etc on the suction line. It is advisable to install a flow meter to check possible changes of value.

Values of performances written on the curves refer to trial pumps during prototype phase. In pumps manufactured in series such values can be lower. Usually these values have to be considered as follows:

- pumps with discharge up to 25mm: - 3 points
- pumps with discharge superior to 25mm: - 2 points

Characteristics of pumps series HTM are guaranteed by the manufacturer with tolerances in accordance with UNI EN ISO 9906:2002 regulation. With respect to other specifications or regulations requiring more restricted tolerances, these have to be specifically asked for at the moment of quotation; in this case GemmeCotti will choose a pump more suitable and the required regulations will be considered.

10 WARRANTY AND REPAIR

10.1 Warranty

All GemmeCotti products are guaranteed for a period of twelve (12) months starting from the delivery date of the goods.

For the warranty service to be applicable the customer must report the defect in writing no later than 8 (eight) days from the moment that the damage occurs, and must return the part (or parts) to GemmeCotti for repair or replacement. Pumps cannot be repaired or substituted on site. In the case of a request of warranty service, it's better to send the complete pump together with its motor to GemmeCotti.

The costs of delivery and the relative risks, and possible customs duties have to be paid by the customer. GemmeCotti will not accept the costs of collection and shipment.

The manufacturer is not responsible for damages caused during the shipment of the parts or of the pump sent to GemmeCotti to be repaired under warranty.

The warranty system provides that, after a careful examination at our factory, GemmeCotti is free to choose to repair or replace the part (or parts) of the pump which is/are defective in materials or in workmanship, or both. We will not give any refund or credit for the defective material or for direct or indirect damages caused by our pumps. In any case, any reimbursement cannot exceed the cost of the pump or of the supplied material.

If the pumped liquid and the needed performances have not been communicated to GemmeCotti before the offer and confirmed in the quotation and order confirmation and/or the pump is not properly installed, maintained and used for its intended purpose or under conditions which can reasonably be foreseen as indicated in the Machine Directive 2006/42/CE article 4 paragraph 1, the customer takes the whole responsibility for the usage of the product, especially if not used in an appropriate way, and the warranty, the conformity to the Machine Directive 2006/42/CE and the relative CE declaration are no longer valid. The proper installation, maintenance and use for its intended purpose and the conditions which can reasonably be foreseen are subject to the respect of the technical limits (temperature, working point, compatibility of the pump material with the pumped fluid, NPSH etc...) which are indicated in GemmeCotti's technical data files and use and maintenance manuals.

If the above mentioned limits are not respected, the customer is the only responsible for the introduction of the pump in the market, for the declaration of conformity to the Machine Directive and the CE mark. In any case the user is considered the one who knows better the chemical compatibility and the reactions between the liquid to be pumped and the material of construction of the pump and consequently the information given in this regard by GemmeCotti is merely indicative.

If the returned piece is no longer covered by guarantee, or if after inspection GemmeCotti finds the piece to be not defective, inspection charges will be charged to the customer and the repaired or substituted piece will be returned to the customer at the customer's own expense. Pumps which have been repaired or substituted under guarantee will be supplied on the same delivery conditions as the order and the warranty will not be extended.

Warranty does not cover components subject to natural wear due to time, such as mechanical seals, bearings, bushings and lip seals.

The customer is solely responsible for the good performance of pumps and for their careful maintenance. Therefore no claims will be allowed when goods have been improperly handled (not stored in a suitable closed dry place, which is necessary because of the fragility of materials), contaminated, handled with negligence, improperly installed, tampered with or not well regulated, incorrectly used in wrong applications. In particular, GemmeCotti will not take any responsibility in the case of wear due to corrosion.

Ordinary repairs and/or maintenance must be carried out in accordance with the instructions indicated in the manual and carried out by pumps experts. Any case of pump tampering or modification, the warranty and the CE declaration will lose their validity. In this case, the customer will assume the product risk and he must issue a new CE declaration of conformity. The warranty does not cover damages due to extraordinary or natural events, such as lightning, ice, fire and others.

All the warranty obligations are considered fully satisfied after the repair or substitution of the defective parts.

The Warranty service will be suspended in the case of default or delayed payment and the period lost cannot be recovered.

This warranty is an integral part of the offer and of the order confirmation.

In the case of litigation the court which has jurisdiction is the Busto Arsizio (Italy) Tribunal and the law that will be applied is the Italian Law.

2. 9.2 Returned parts and repair

All our distributors offer a complete repair service. Contact your local distributor or GemmeCotti s.r.l. directly.

Before sending the pump back to our repair services or to GemmeCotti, the pumps have to be decontaminated from the used dangerous liquids. Before sending the pump the customer has to fill in the Decontamination Declaration and send it by e-mail as per the facsimile document in the next paragraph 9.3

10 .3 Decontamination Declaration ³ (facsimile)

GemmeCotti European Pumps
Via Po 23/25/27 – 20031 Cesate(MI)
Telephone 02.964.60.406–Fax 02.964.69.114

SUBJECT: Decontamination Declaration of pumps to be repaired

Reference to our Transport document No: _____ dated: _____

Type of pump: _____ Serial Number: _____

Fluid pumped: _____

Type of problem/damage: _____

In accordance with current requirements regarding the health and safety of workmen, we hereby declare that:

- 1. The pump has been carefully cleaned and decontaminated to remove all traces of the pumped fluid
- 2. Also the residual fluid used to decontaminate the pump has been removed
- 3. It is possible to proceed with the repair of the pump without risks for the workmen or the environment

Attention: if the pump is not correctly cleaned or we do not receive this document duly filled in, it will be sent back at the customer's expense

Date _____

STAMP AND SIGNATURE

³ TO BE COMPLETED ON THE CUSTOMER'S LETTERHEAD PAPER

10 .4 CE CERTIFICATE FOR PUMPS SERIES HTM PP/PVDF

Declaration of Conformity⁴ (facsimile) to the Machine Directive 2006/42/CE

CE DECLARATION OF CONFORMITY

We declare under our sole responsibility that the pump:

Brand: GEMMECOTTI

Guy :

Model:

Serial number:

Year:

as per described in attached documentation, is in accordance with the Machine Directive CE 2006/42 (ex 89/392/CEE - 91/368/CEE - 93/44/CEE – 93/68/CEE-98/37 CEE) only if it's used for the liquids communicated by the customer..... and for the pump characteristics required with regard to the order No.....dated.....

If the pumped liquid and the needed performances have not been communicated to GemmeCotti and/or the pump is not properly installed, maintained and used for its intended purpose or under conditions which can reasonably be foreseen, the customer takes the whole responsibility of the products as indicated in our warranty Mod. 1.11.4E.

The conformity to the previously mentioned requirements is expressed by the marking:



ENRICO GEMME

CESATE,

Signature

⁴ In cases where the customer does not communicate the type of liquid used in the pump and the expected operating conditions, the EC Declaration of Conformity will not be issued and the customer will assume the responsibility and burden of providing certification of the pump in its application.

10.5 ATEX/CE certificate for zone 2 (facsimile)



EU Declaration of conformity

The magnetic drive pump type:

SN

Together with all the pumps series:

EM(-C-T-P) PP/PVDF
bearing the mark:

CE Ex II 3G Ex h IIB T6 Gc

models:

EM-C 6 PP/PVDF, EM-C 10 PP/PVDF, EM-C 15 PP/PVDF, EM-C 31 PP/PVDF, EM-C 40 PP/PVDF, EM-C 50 PP/PVDF, EM-T 2000 PP/PVDF, EM-T 3000 PP/PVDF, EM-T 5000 PP/PVDF, EM-T 7000 PP/PVDF, EM-T 9000 PP/PVDF, EM-T 12000 PP/PVDF, EM-T SP 5000 PP/PVDF, EM-T SP 7000 PP/PVDF, EM-T SP 9000 PP/PVDF, EM-P 100 PP/PVDF, EM-P 200 PP/PVDF, EM-P 300 PP/PVDF, EM-P 400 PP/PVDF, EM-P 600 PP/PVDF, EM-P 800 PP/PVDF

have been manufactured by GemmeCotti s.r.l. in accordance with the following EC directives:

2014/34/EU (ex 94/9 EC), 2006/42 EC

and the following standards:

EN 12100, EN 13857, EN 809, EN 1127-1, EN 80079-36, EN 80079-37

The manufacturing process is internally controlled by a Quality Management System according to ISO 9001:2015 standards and the internal control of production file n. 101 ext. 01/07, is deposited at GESI, notified body N.0722.

This declaration of conformity is issued under the sole responsibility of the manufacturer.



ATTENTION: the above magnetic drive pumps, considered as components, comply by design with the directive providing that installation is correctly performed by the manufacturer of the machinery. The pump must not be put on duty until the machinery or plant into which it has been incorporated is declared in conformity with the Machinery Directive. This declaration does not imply any warranty of properties. The safety instruction of the accompanying product documentation shall be observed.

Since there is an endless variety of products and chemical compositions that can be suitable to be processed by the considered devices, the end user is the only responsible to verify the reactions and suitability with materials used to build the pump. Therefore, all necessary tests and checks must be performed with great care to avoid any risk, and any adverse event that cannot be foreseen by the manufacturer and of which the manufacturer cannot be held responsible. Every dispute lies within competence of Varese Court.

Enrico Gemme
General Manager

Cesate, Date: _____



Via Po 23-25-27 - 20031 - Cesate (MI) ITALY - EU

www.gemmecotti.com

Tel. +39 02 96480408 - info@gemmecotti.com

Mod 4.2.1 (ICTP)